

Wireless Network Security

Lecture 6

Confidentiality and Authentication based on Physical-layer

Srdjan Čapkun

Can we leverage the Physical Layer for
Confidentiality? Authentication? Access
Control?

Recommended Readings

- On the Limitations of Friendly Jamming for Confidentiality. Nils Ole Tippenhauer, Luka Malisa, Aanjhan Ranganathan, Srdjan Capkun (IEEE Symposium on Security and Privacy 2013)
- MIMO 1 : Spatial Multiplexing and Channel Modeling. Chapter 7 of Fundamentals of Wireless Communication. Tse and Vishwanath.

Channel-based Key Establishment

Wireless Channel

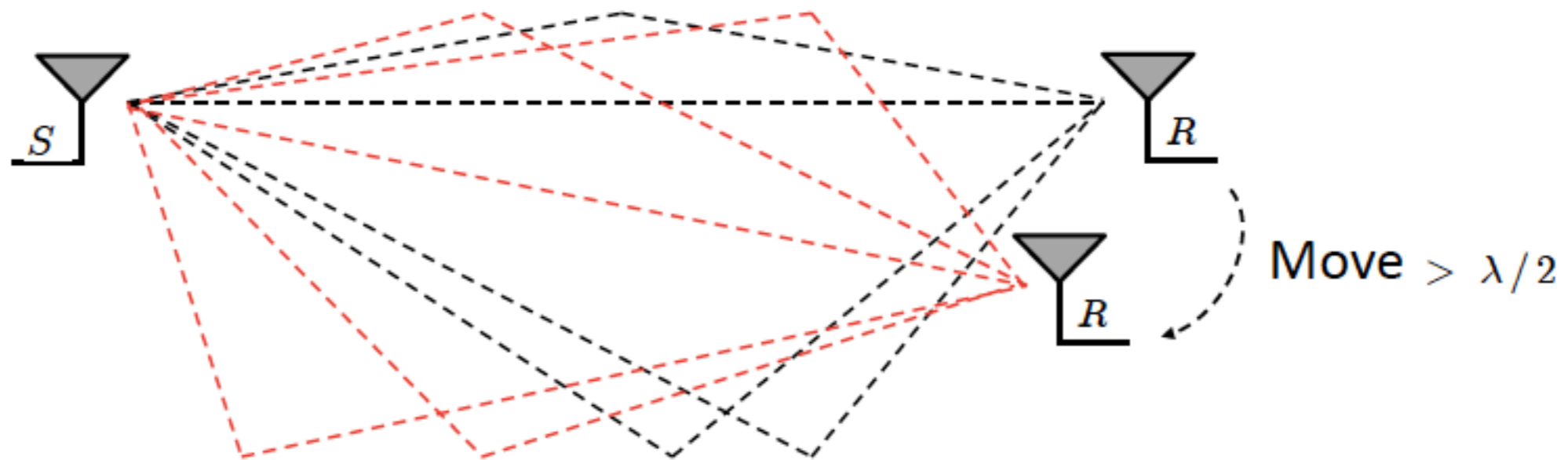

- In a complex, multipath-rich environment, channels exhibit time-varying, stochastic and reciprocal fading.
- For receivers that are $> \lambda/2$ away, channels are not correlated.

=> the channel between S and R will be 'random' and will not be

known to the attacker

=> a natural wiretap channel

Wireless Channel

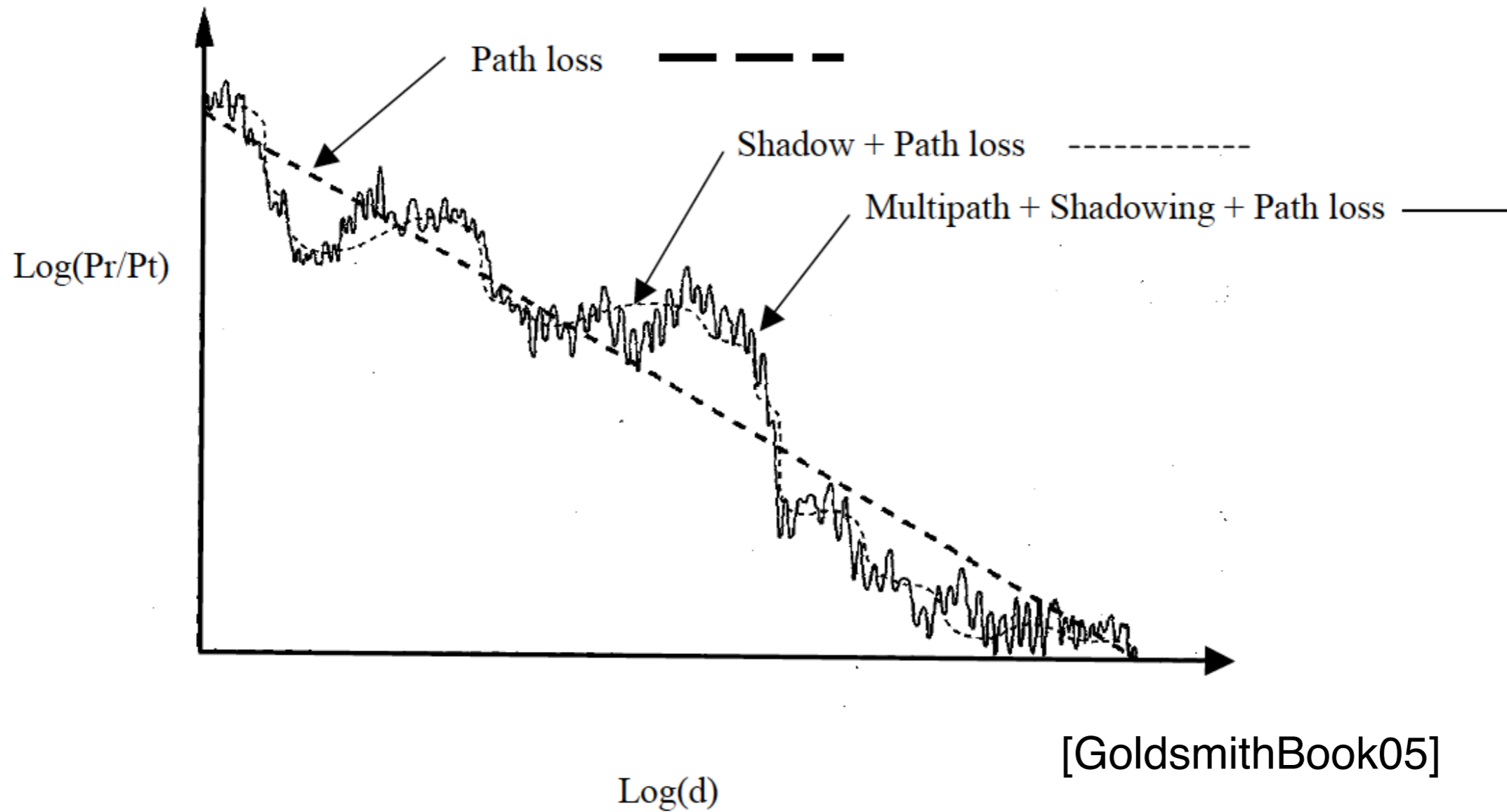

- the attacker does not know and cannot remotely measure multipath fading components

Key Agreement: RSSI [MathurMobiCom08]

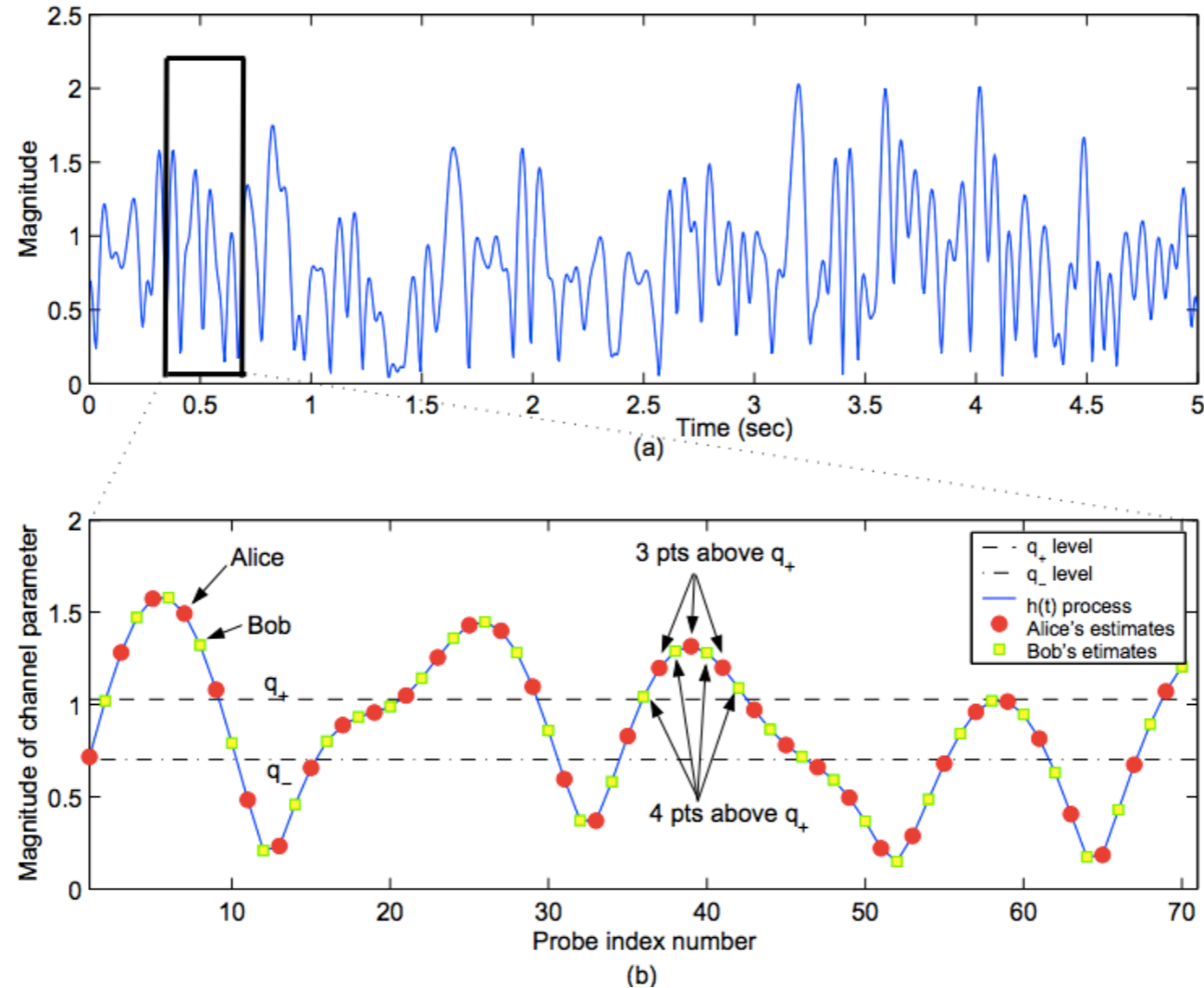

1. Signal Acquisition and Quantization
2. Reconciliation (error correction, privacy amplification)
3. Key confirmation

Key Agreement

Channel property^a	RSSI [17,18,10,19,1,16,13]	CIR [12,1,13,14]	Phase [15]
Entropy source	Movement [17,10,19,12,11,1,13,14]	Channel-selective fading [16]	Angle of arrival [18]
Hardware	802.15.4 [17,18,19,11,16]	UWB [10,12]	802.11a [1,13]
Quantization	1-threshold [18,10]	2-thresholds [17,12,1,13]	Dynamic multi- threshold [19,11,15,16,14]
Error correction	Block-based parity [17]	Quantization- dependent [18,10,19,12,1,16]	Error correction codes [13,14]
Attacker model	Passive [17,18,10,19,12,15,16,14]	Active [11,1,13]	—

^a Some protocols use multiple channel properties.

[EberzESORICS12]

- A broad range of HW assumptions.

Analysis

Analysis

- No authentication!
 - Secret key established but with which device?
 - Cannot use channel information to authenticate

Analysis

- No authentication!
 - Secret key established but with which device?
 - Cannot use channel information to authenticate
- No guarantees on the environment
 - Is the environment multipath-rich?
 - Can attacker pre-measure environment [TmarPhD2012]?
 - Can attacker be verified to be $> \lambda/2$ away?

Analysis

- No authentication!
 - Secret key established but with which device?
 - Cannot use channel information to authenticate
- No guarantees on the environment
 - Is the environment multipath-rich?
 - Can attacker pre-measure environment [TmarPhD2012]?
 - Can attacker be verified to be $> \lambda/2$ away?
- Questionable benefits over existing PK/SK schemes
 - Information-theoretic guarantees claimed in some papers but unclear how these hold.

Analysis

- No authentication!
 - Secret key established but with which device?
 - Cannot use channel information to authenticate
- No guarantees on the environment
 - Is the environment multipath-rich?
 - Can attacker pre-measure environment [TmarPhD2012]?
 - Can attacker be verified to be $> \lambda/2$ away?
- Questionable benefits over existing PK/SK schemes
 - Information-theoretic guarantees claimed in some papers but unclear how these hold.
- Most schemes consider only passive adversary

Analysis

- No authentication!
 - Secret key established but with which device?
 - Cannot use channel information to authenticate
- No guarantees on the environment
 - Is the environment multipath-rich?
 - Can attacker pre-measure environment [TmarPhD2012]?
 - Can attacker be verified to be $> \lambda/2$ away?
- Questionable benefits over existing PK/SK schemes
 - Information-theoretic guarantees claimed in some papers but unclear how these hold.
- Most schemes consider only passive adversary
- Active attacks
 - Influence and discover the established key.
[EberzESORICS12]
 - Abuse the lack of authentication

Ensuring Secrecy with MIMO

- Approaches:
 - Zero Forcing
 - Orthogonal Blinding

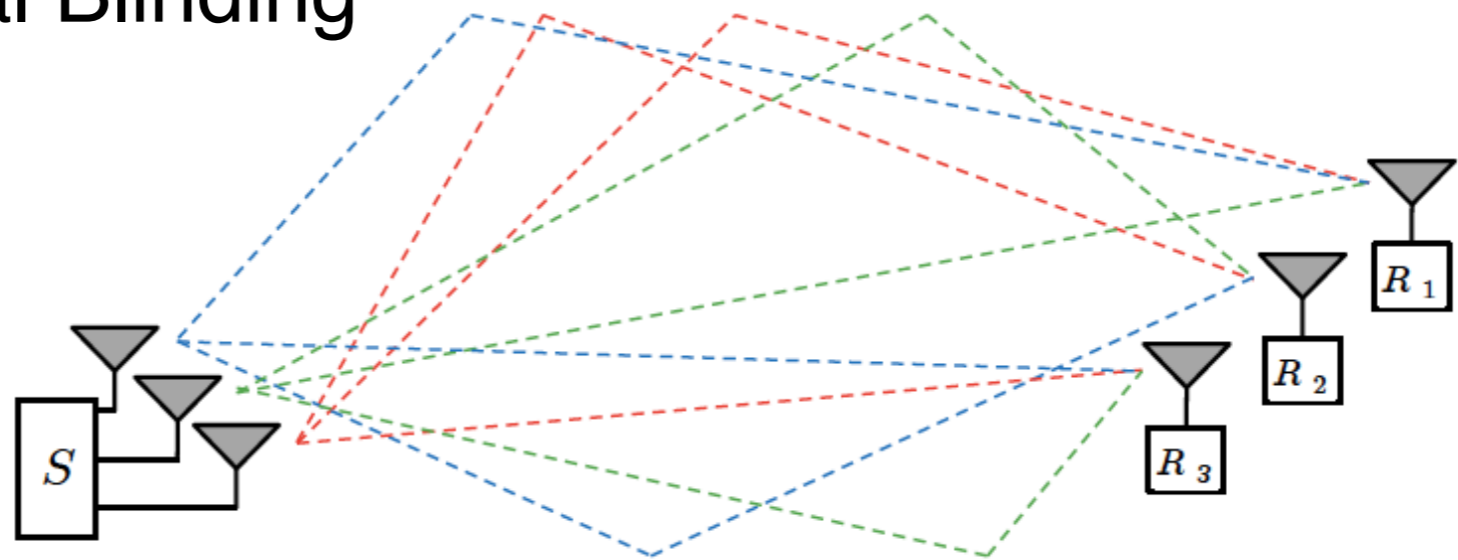

- Main ideas:
 - Steer the signals towards the receiver and away from the attacker.
 - Use jamming to interfere with the attacker, but not with the receiver.

Modeling the Channel

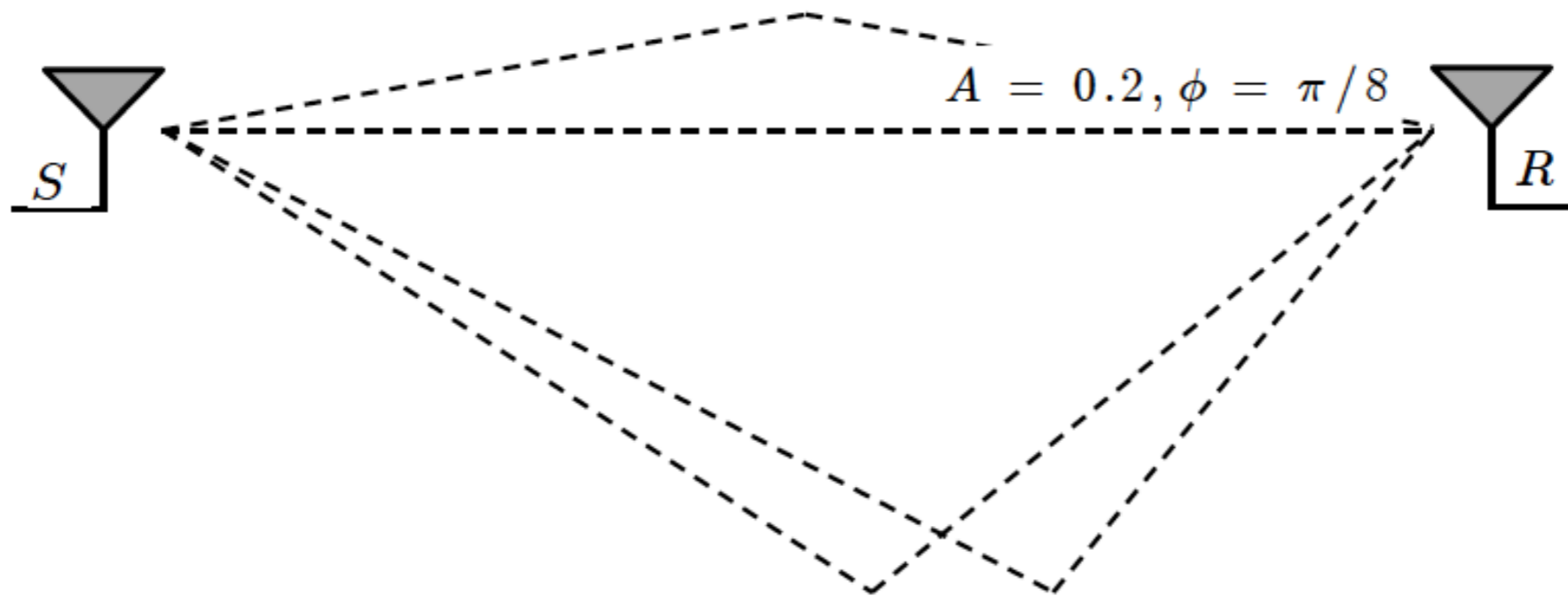

- At the receiver, signal has different phase and amplitude
- Channel is modeled as a single complex number
 - Captures both change in amplitude (real part) and phase (imaginary part).
 - Represents cumulative effects of all multipath components.

Zero Forcing

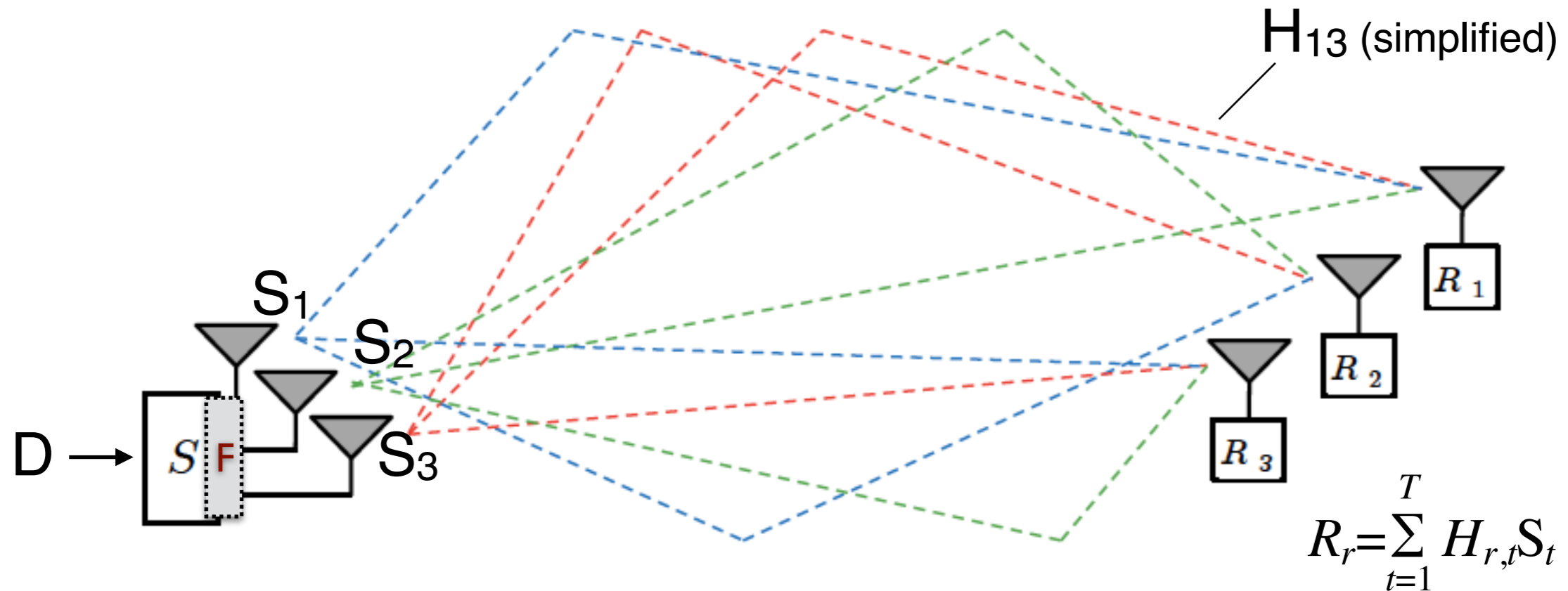

- S knows the channels to R_1 and to attackers R_2, R_3
- $R = H \mathbf{F} D = H S$
- H : channel matrix
- D : data matrix (conf. data)
- \mathbf{F} is a transmission filter, constructed given H , s.t.:
 - $R_1 =$ confidential data
 - $R_2, R_3 =$ no (useful) data

Orthogonal Blinding

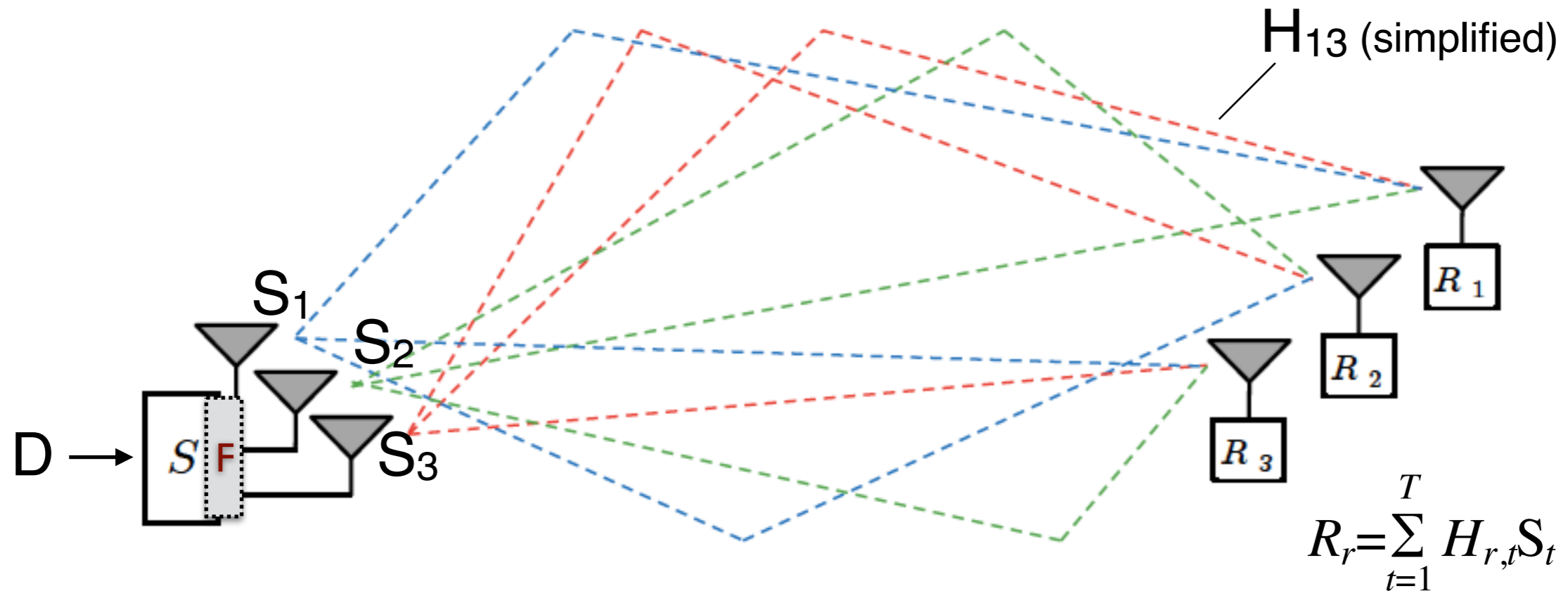

- S knows the channels to R_1 **but not to attackers**
- $R = H F D = H S$
- H : channel matrix (part randomly generated)
 D : data matrix (conf. data and noise)
- F is a transmission filter, constructed given H , s.t.:
 - $R_1 =$ confidential data
 - R_2, R_3 (**attackers**) = **data + jamming signal (noise)**

Analysis

Analysis

- Stronger guarantees than SISO schemes:
 - beamforming focuses the energy to the receiver
 - jamming interferes with the attacker

Analysis

- Stronger guarantees than SISO schemes:
 - beamforming focuses the energy to the receiver
 - jamming interferes with the attacker

Analysis

- Stronger guarantees than SISO schemes:
 - beamforming focuses the energy to the receiver
 - jamming interferes with the attacker
- No authentication!

Analysis

- Stronger guarantees than SISO schemes:
 - beamforming focuses the energy to the receiver
 - jamming interferes with the attacker
- No authentication!
- No guarantees on the environment

Analysis

- Stronger guarantees than SISO schemes:
 - beamforming focuses the energy to the receiver
 - jamming interferes with the attacker
- No authentication!
- No guarantees on the environment
- Questionable benefits over existing PK/SK schemes

Analysis

- Stronger guarantees than SISO schemes:
 - beamforming focuses the energy to the receiver
 - jamming interferes with the attacker
- No authentication!
- No guarantees on the environment
- Questionable benefits over existing PK/SK schemes

Analysis

- Stronger guarantees than SISO schemes:
 - beamforming focuses the energy to the receiver
 - jamming interferes with the attacker
- No authentication!
- No guarantees on the environment
- Questionable benefits over existing PK/SK schemes
- Passive attacks: known plaintext attack [SchulzNDSS2013]
 - **Attacker trains a filter until it finds a plaintext and thus discovers the channel between S and R.**

Analysis

- Stronger guarantees than SISO schemes:
 - beamforming focuses the energy to the receiver
 - jamming interferes with the attacker
- No authentication!
- No guarantees on the environment
- Questionable benefits over existing PK/SK schemes
- Passive attacks: known plaintext attack [SchulzNDSS2013]
 - **Attacker trains a filter until it finds a plaintext and thus discovers the channel between S and R.**
- Active attacks:
 - Abuse the lack of authentication.

Can we use Friendly Jamming for Confidentiality
and Access Control

Jamming for Confidentiality

- The use of jamming for
 - **confidentiality**
 - authentication / access control
 - S.Goel, R.Negi, “Guaranteeing secrecy using artificial noise,” IEEE T. on Wireless 2008
 - A. Araujo, J. Blesa, E. Romero, and O. Nieto-Taladriz, “Cooperative jam technique to increase physical-layer security in CWSN 2012
 - L. Dong, Z. Han, A. Petropulu, and H. Poor, “Cooperative jamming for wireless physical layer security,” in Proc. of IEEE Workshop on Statistical Signal Processing (SSP), 2009
 - X. Tang, R. Liu, P. Spasojevic and, and H. Poor, “Interference assisted secret communication,” IEEE Transactions on Information Theory, vol. 57, no. 5, pp. 3153 –3167, May 2011.
 - J. Vilela, M. Bloch, J. Barros, and S. McLaughlin, “Friendly jamming for wireless secrecy,” in Proceedings of the IEEE ICC 2010
 - M. R. Rieback, B. Crispo, and A. S. Tanenbaum, “Keep on blockin’ in the free world: Personal access control for lowcost RFID tags,” in Proc. 13th International Workshop on Security Protocols. LNCS, Apr 2005.
 - I. Martinovic, P. Pichota, and J. Schmitt, “Jamming for good: A fresh approach to authentic communication in wsns,” in Proceedings ACM WiSec. 2009,
 - C. Kuo, M. Luk, R. Negi, and A. Perrig, “Message-in-a-bottle: user-friendly and secure key deployment for sensor nodes,” in Proceedings of SenSys 2007.
 - ...

Jamming for Confidentiality

- Orthogonal blinding / Zero forcing:
transmit noise into the null-space of the receiver's channel
 - no pre-established secrets
 - used for key establishment
- **Friendly Jamming:**
transmit noise which the receiver subtracts
 - Receiver knows the seed used to generate the noise.
 - Eavesdropper cannot separate signal and noise.

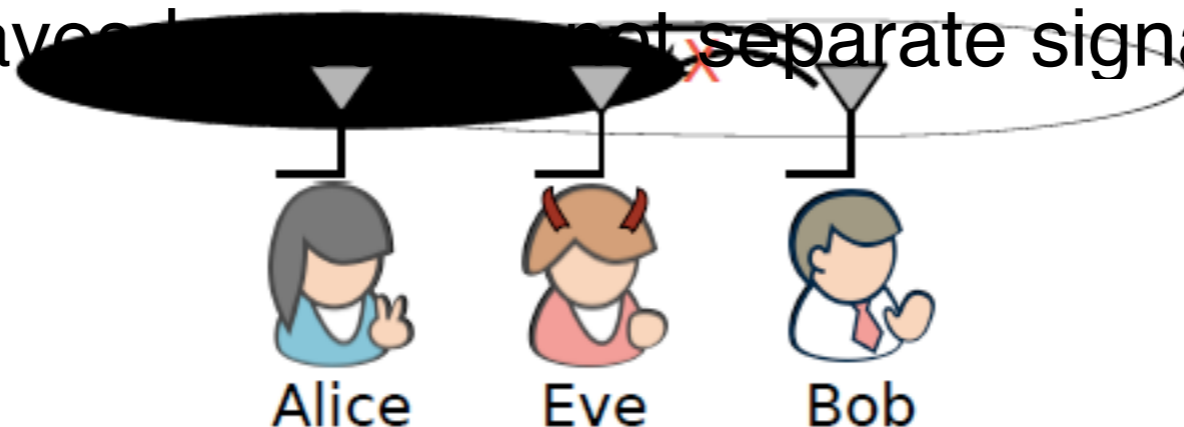

Friendly Jamming



- Jamming signal is much stronger and covers the spectrum of the data signal.
- If $DJ > \lambda/2$, attacker equipped with two antennas can separate signals from J and D (different channels).
- If $DJ \gg \lambda/2$ attacker can use directional antennas to separate the signals.
- \Rightarrow the only “safe” case seems to be when $DJ < \lambda/2$

Example: “IMD Shield”

- S. Gollakota, H. Hassanieh, B. Ransford, D. Katabi, K. Fu, “They can hear your heartbeats: Non-invasive security for implanted medical devices,” in Proceedings of the ACM SIGCOMM 2011

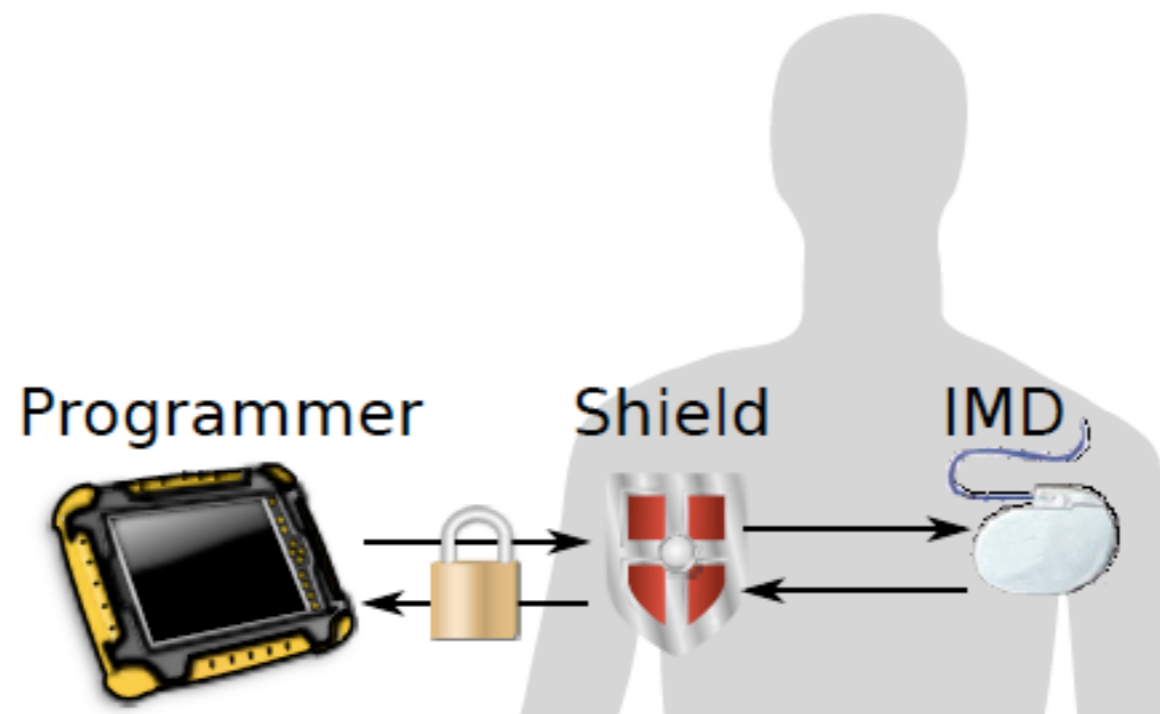

- Confidentiality:
 - IMD Shield jams the eavesdropper.
 - Legitimate reader jammed but can remove jamming signal (shared key with the Shield).

Example: “IMD Shield”

- S. Gollakota, H. Hassanieh, B. Ransford, D. Katabi, K. Fu, “They can hear your heartbeats: Non-invasive security for implanted medical devices,” in Proceedings of the ACM SIGCOMM 2011

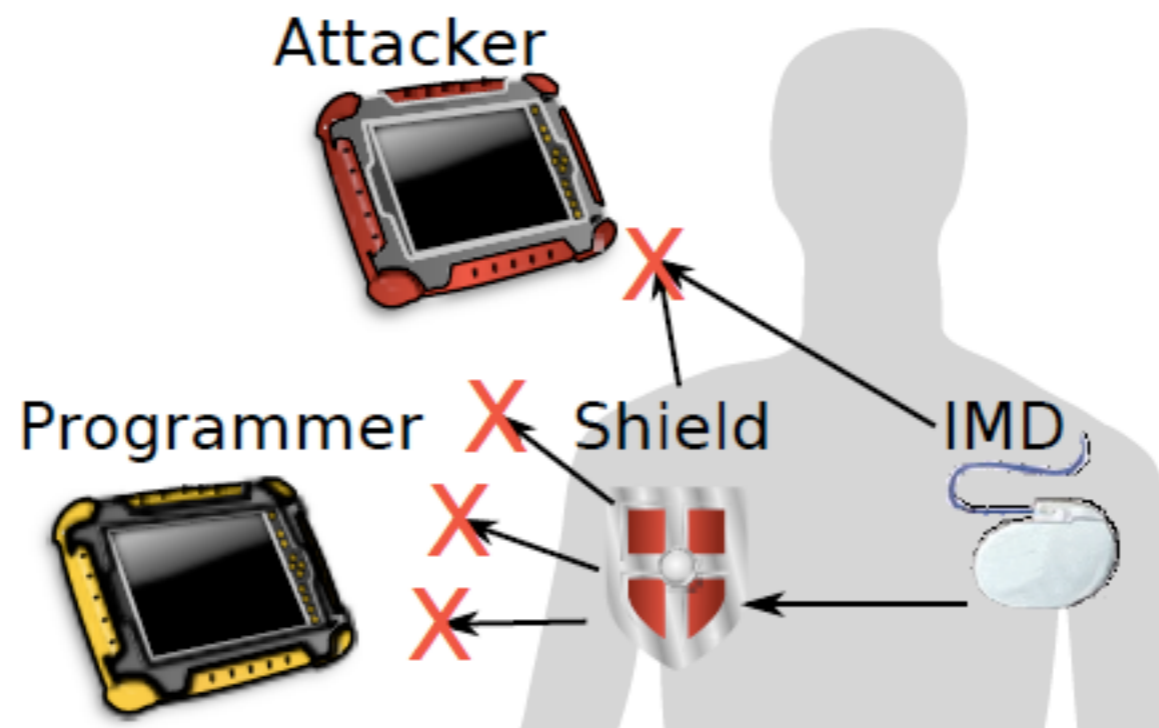

- Confidentiality:
 - IMD Shield jams the eavesdropper.
 - Legitimate reader jammed but can remove jamming signal (shared key with the Shield).

Friendly Jamming Security Arguments



- One of the main security assumptions:
 - If $DJ < \lambda/2$, the attacker cannot separate signals from J and D irrespective of the number of antennas or their directionality.
- However,
 - Confidentiality holds only for a single-antenna attacker.
 - **A MIMO-like attacker CAN separate the signals and recover the confidential message, from a number of locations.**

Attacker Model

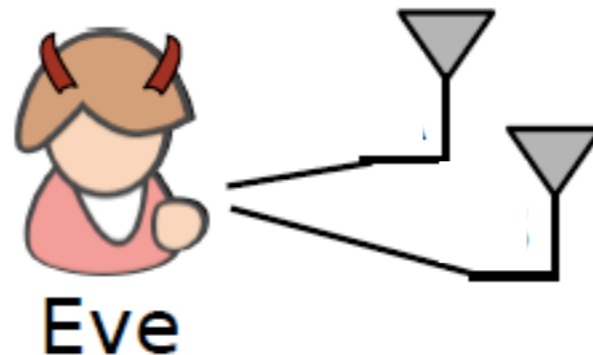

- Passive attacker
 - Two antennas, free placement
 - IMD send private data in plain text
 - Attacker's goal is to break confidentiality i.e., recover data with $BER < 50\%$

LoS Model of the System

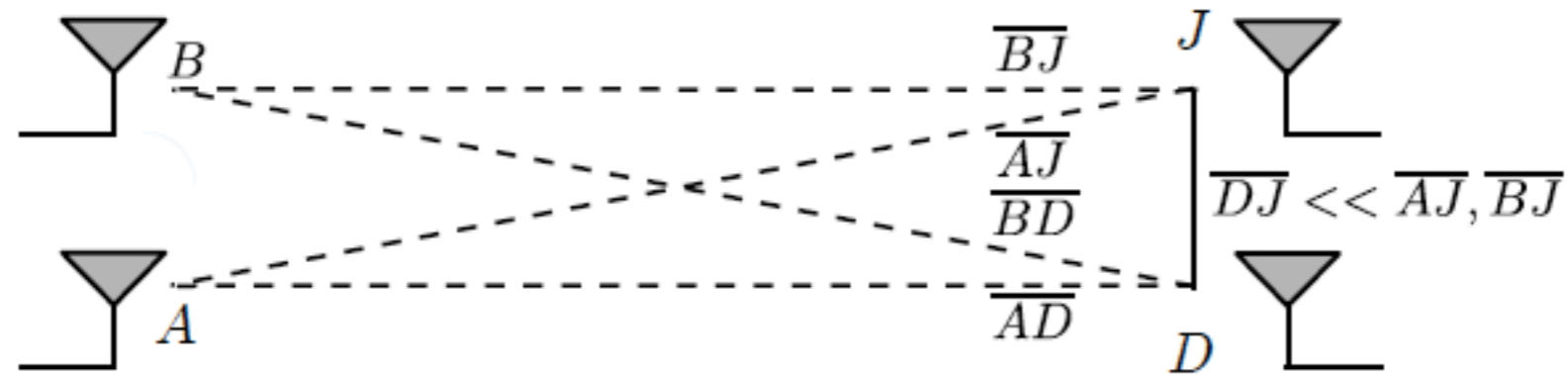

- A and B receive data and jamming signals with different relative offsets.
- ToAs of signals are given by the geometry.
In LOS settings:

$$Y_A(t) = X_D(t - \overline{AD}/c) + X_J(t - \overline{AJ}/c) \text{ and}$$

$$Y_B(t) = X_D(t - \overline{BD}/c) + X_J(t - \overline{BJ}/c)$$

- Each attacker's antenna (A and B) are still jammed.

Ideal Placement of the Attacker's Antennas

- N. Tippenhauer, L. Malisa, A. Ranganathan, S. Capkun, On Limitations of Friendly Jamming for Confidentiality, in Proceedings of the IEEE Symposium on Security and Privacy (S&P), 2013

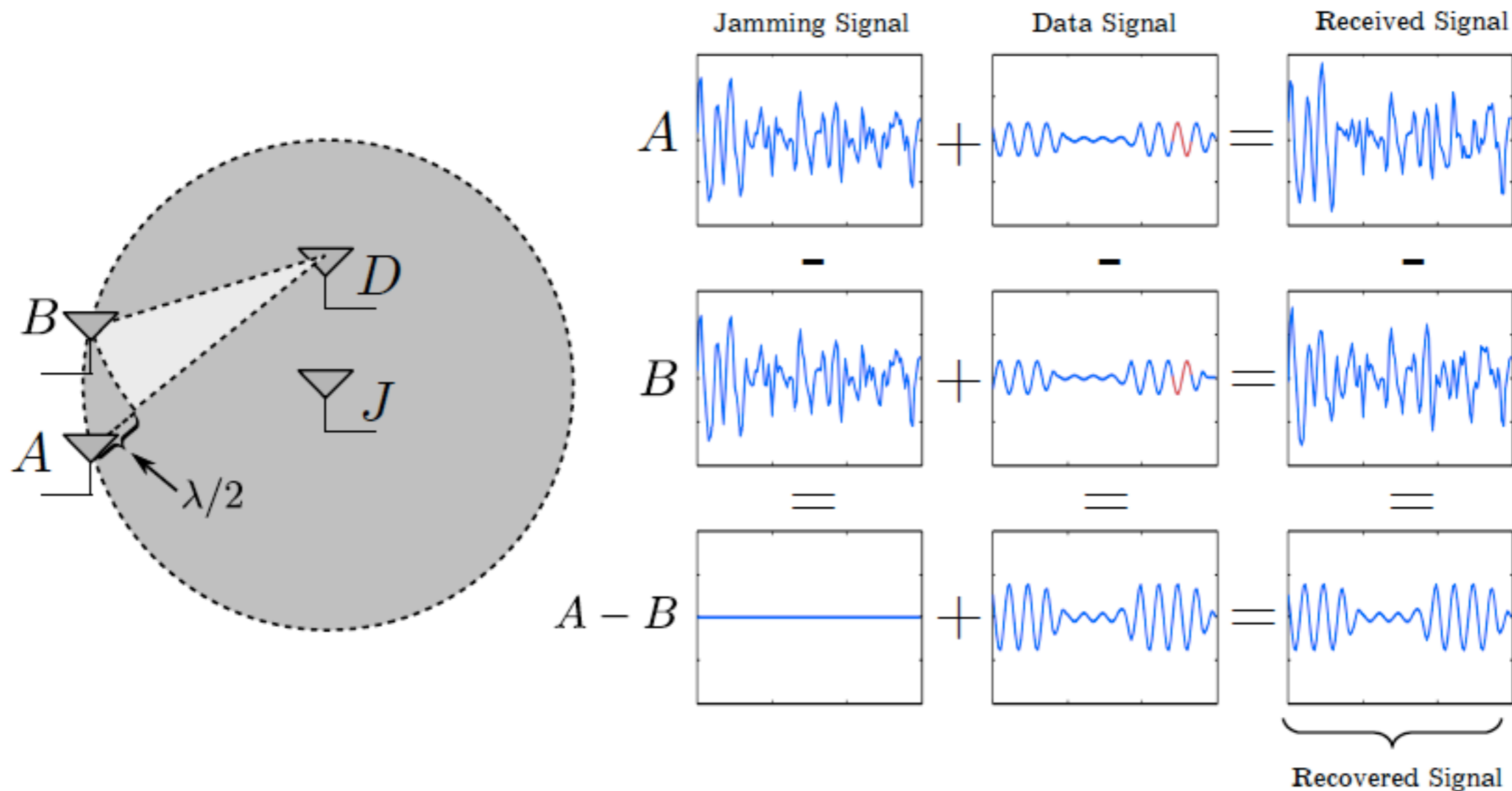

- Jamming signals arrive simultaneously at A and B , data signals are shifted by $\lambda/2$.

Impact of Imperfect Attacker Placement

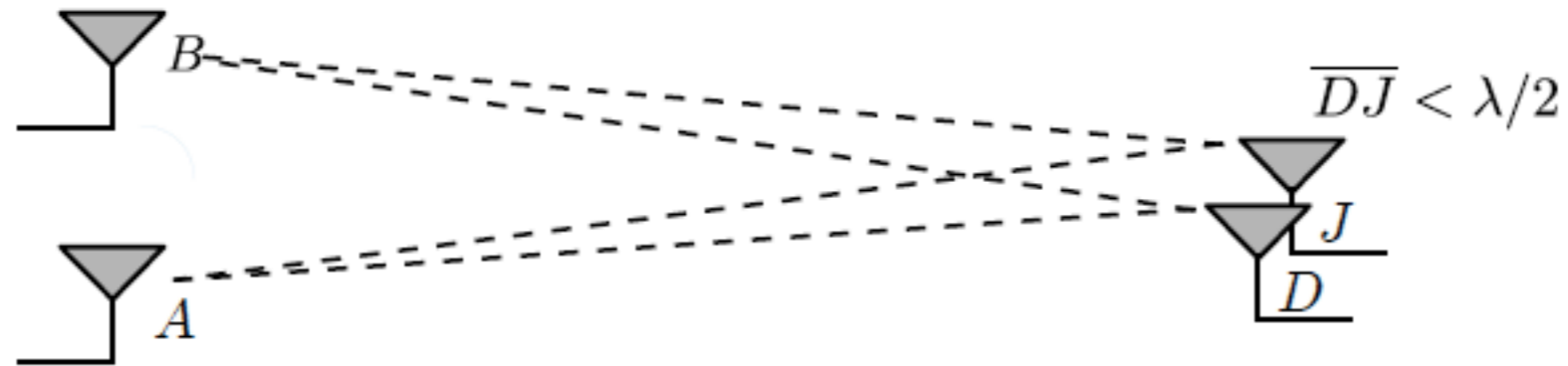

- Ideal cancellation of jamming signal relies on
$$\delta = |(\overline{AJ} - \overline{BJ}) - (\overline{AD} - \overline{BD})| = \lambda/2$$
- For 2.4 GHz WLAN, $\lambda/2 = 6.25\text{cm}$, for 400MHz, $\lambda/2 = 37.5\text{cm}$
- Is data content recovery still possible with imperfect δ ?

Impact of Imperfect Attacker Placement

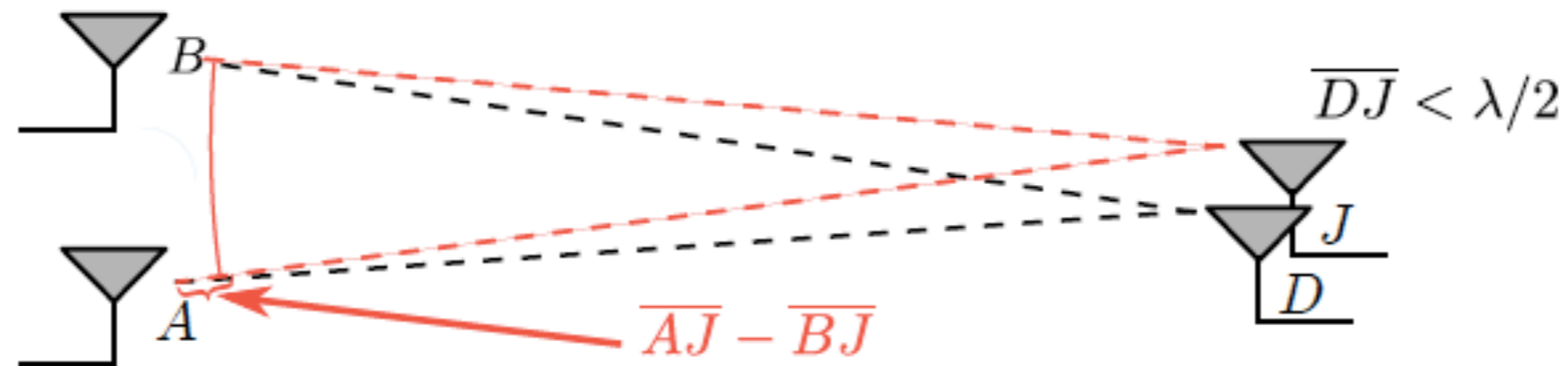

- Ideal cancellation of jamming signal relies on

$$\delta = |(\overline{AJ} - \overline{BJ}) - (\overline{AD} - \overline{BD})| = \lambda/2$$
- For 2.4 GHz WLAN, $\lambda/2 = 6.25\text{cm}$, for 400MHz, $\lambda/2 = 37.5\text{cm}$
- Is data content recovery still possible with imperfect δ ?

Impact of Imperfect Attacker Placement

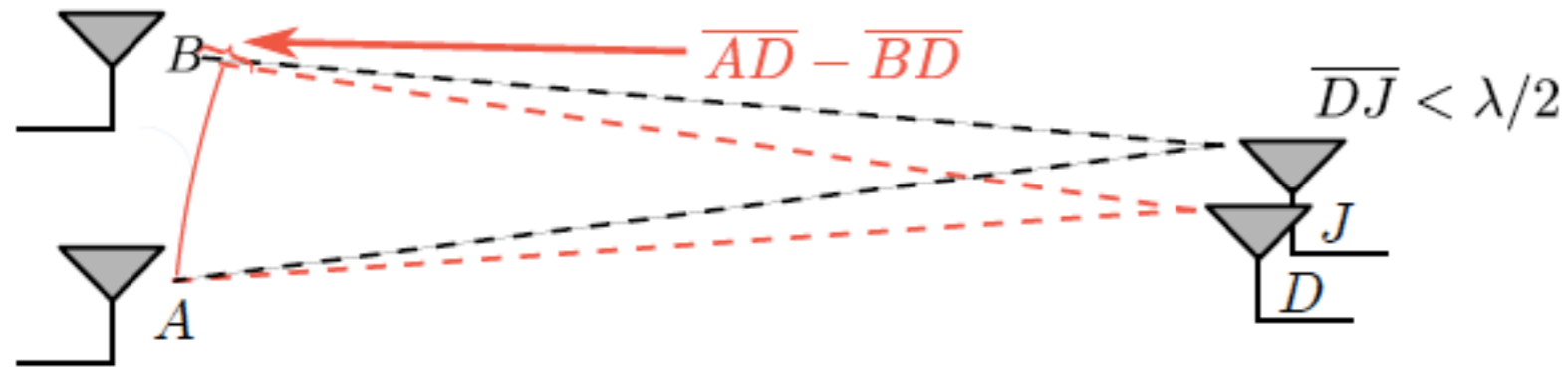

- Ideal cancellation of jamming signal relies on

$$\delta = |(\overline{AJ} - \overline{BJ}) - (\overline{AD} - \overline{BD})| = \lambda/2$$
- For 2.4 GHz WLAN, $\lambda/2 = 6.25\text{cm}$, for 400MHz, $\lambda/2 = 37.5\text{cm}$
- Is data content recovery still possible with imperfect δ ?

Impact of Imperfect Attacker Placement

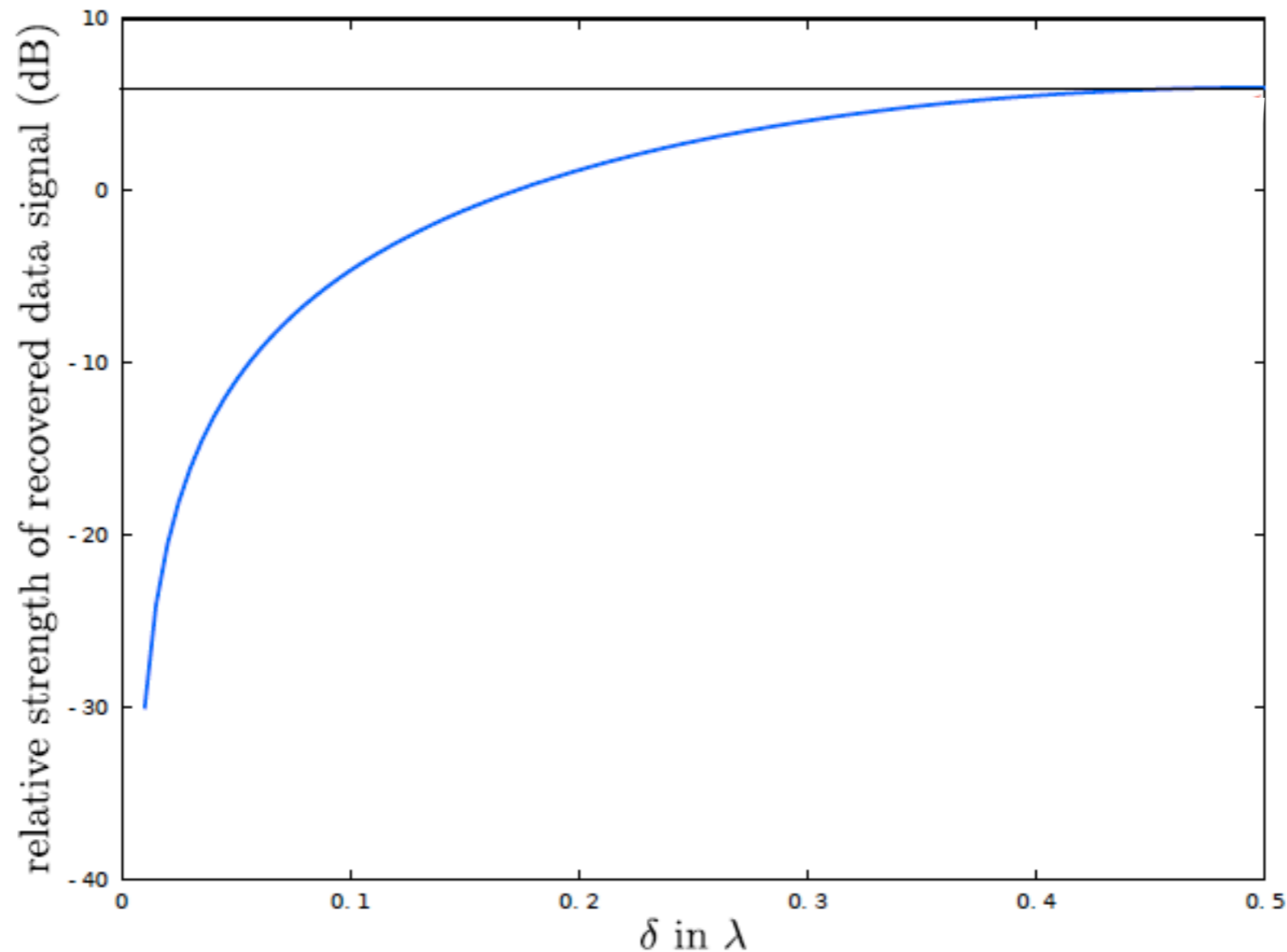

For $\delta = |\overline{AJ} - \overline{AD} - \overline{BJ} + \overline{BD}| > \lambda/5$, the attacker can recover the data signal with amplification (attenuation $< 0dB$).

Impact of Imperfect Attacker Placement

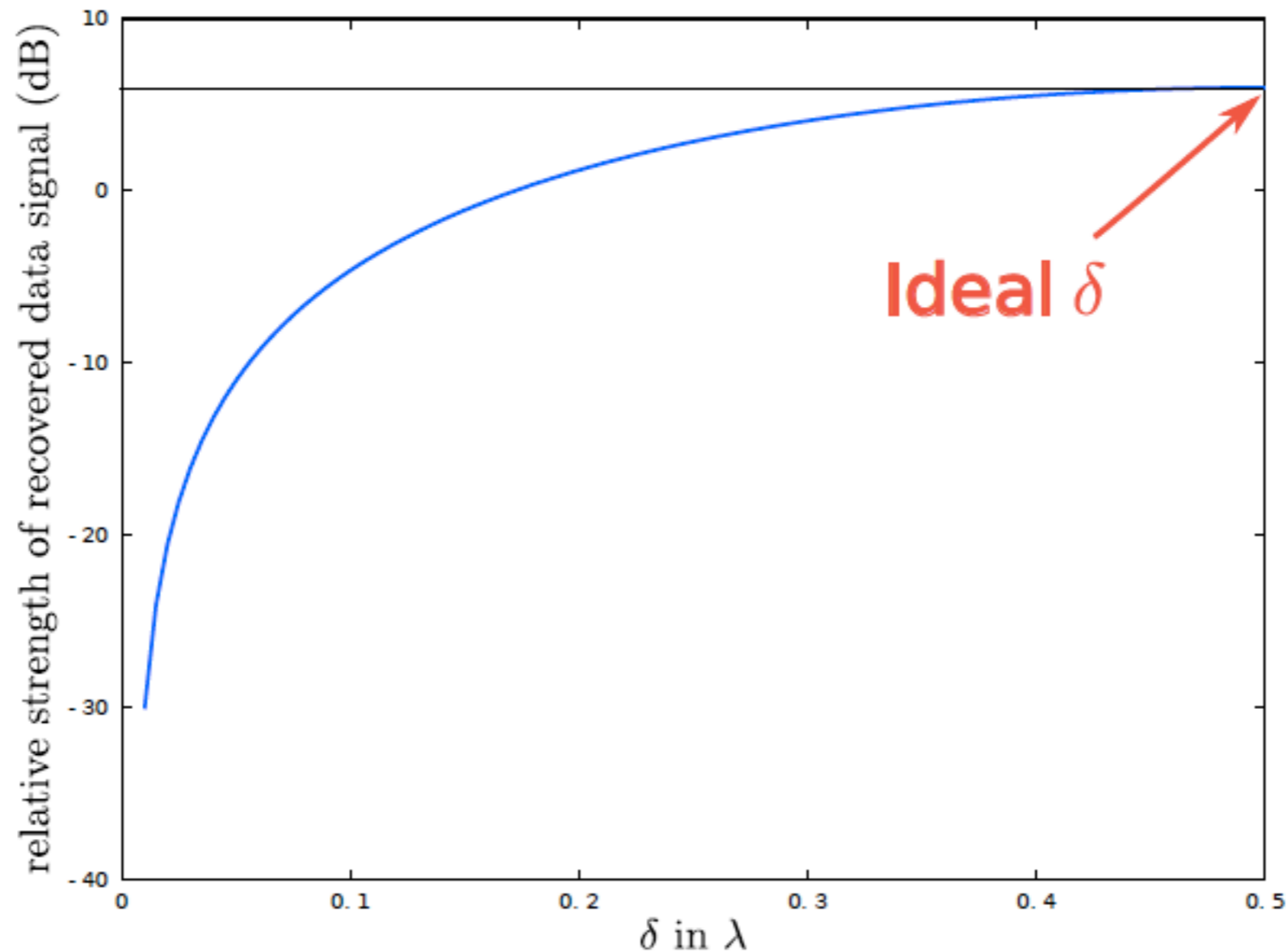

For $\delta = |\overline{AJ} - \overline{AD} - \overline{BJ} + \overline{BD}| > \lambda/5$, the attacker can recover the data signal with amplification (attenuation $< 0dB$).

Impact of Imperfect Attacker Placement

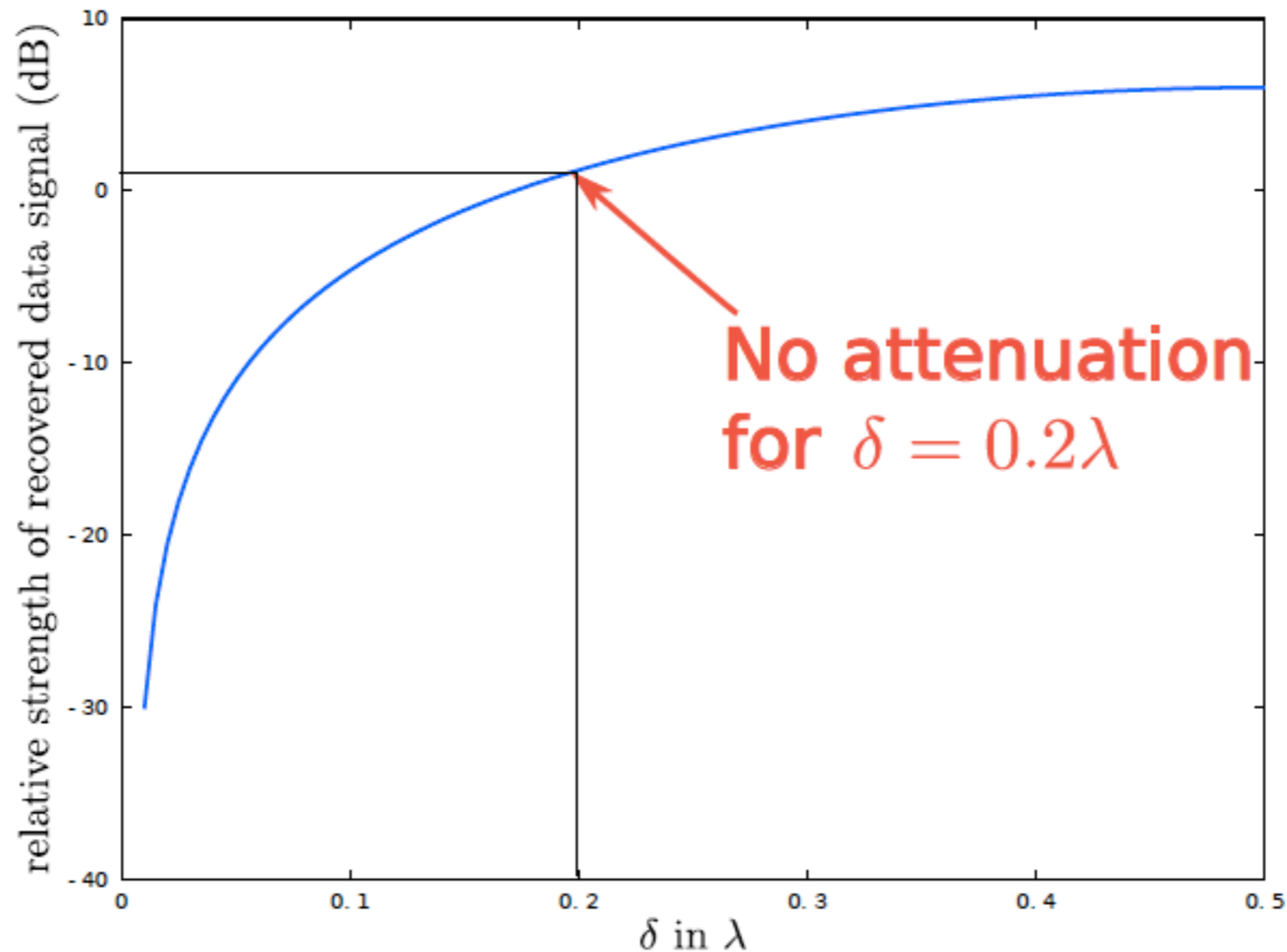

For $\delta = |\overline{AJ} - \overline{AD} - \overline{BJ} + \overline{BD}| > \lambda/5$, the attacker can recover the data signal with amplification (attenuation $< 0dB$).

Impact of Imperfect Attacker Placement

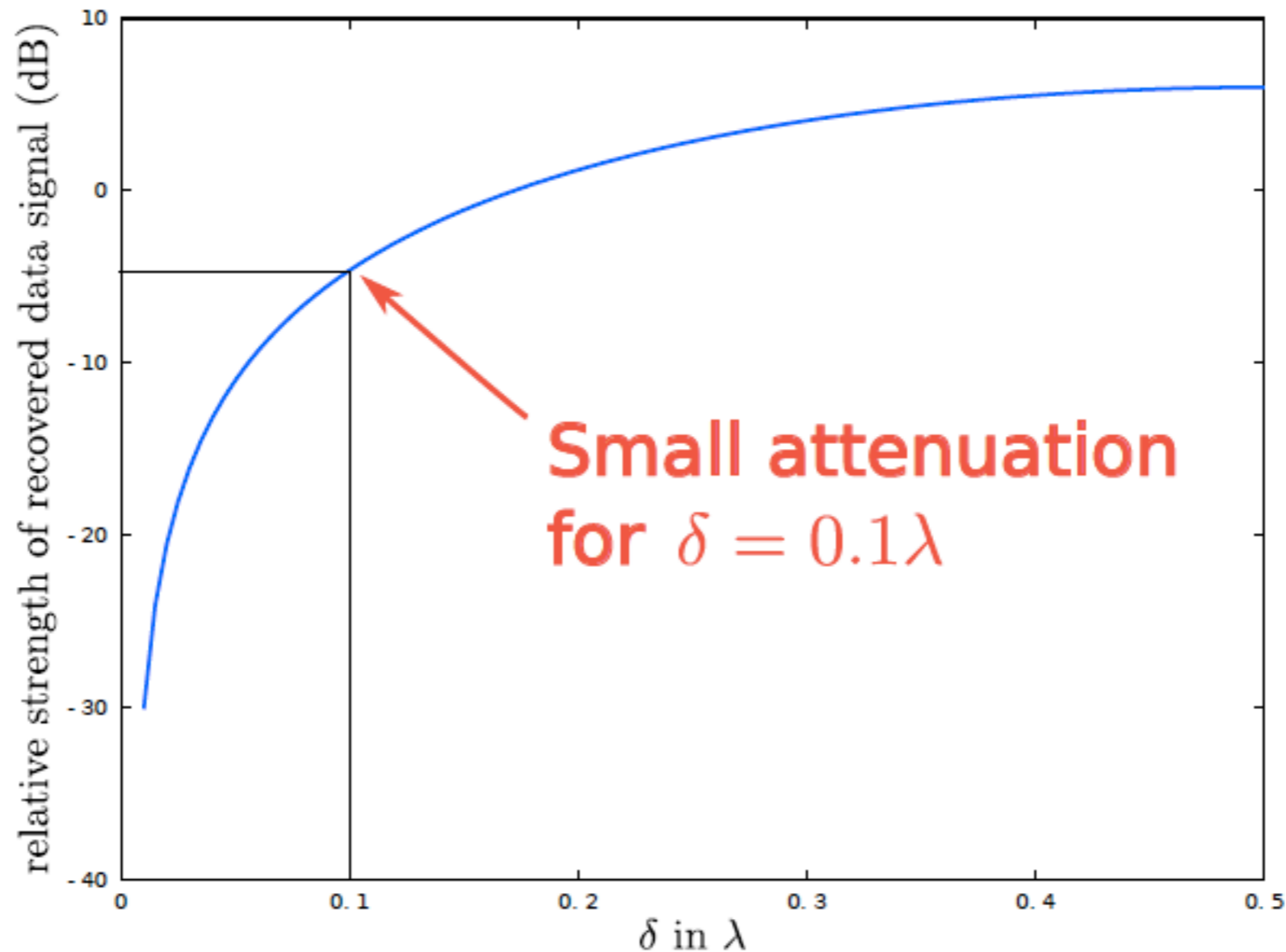

For $\delta = |\overline{AJ} - \overline{AD} - \overline{BJ} + \overline{BD}| > \lambda/5$, the attacker can recover the data signal with amplification (attenuation $< 0dB$).

Simulation Results

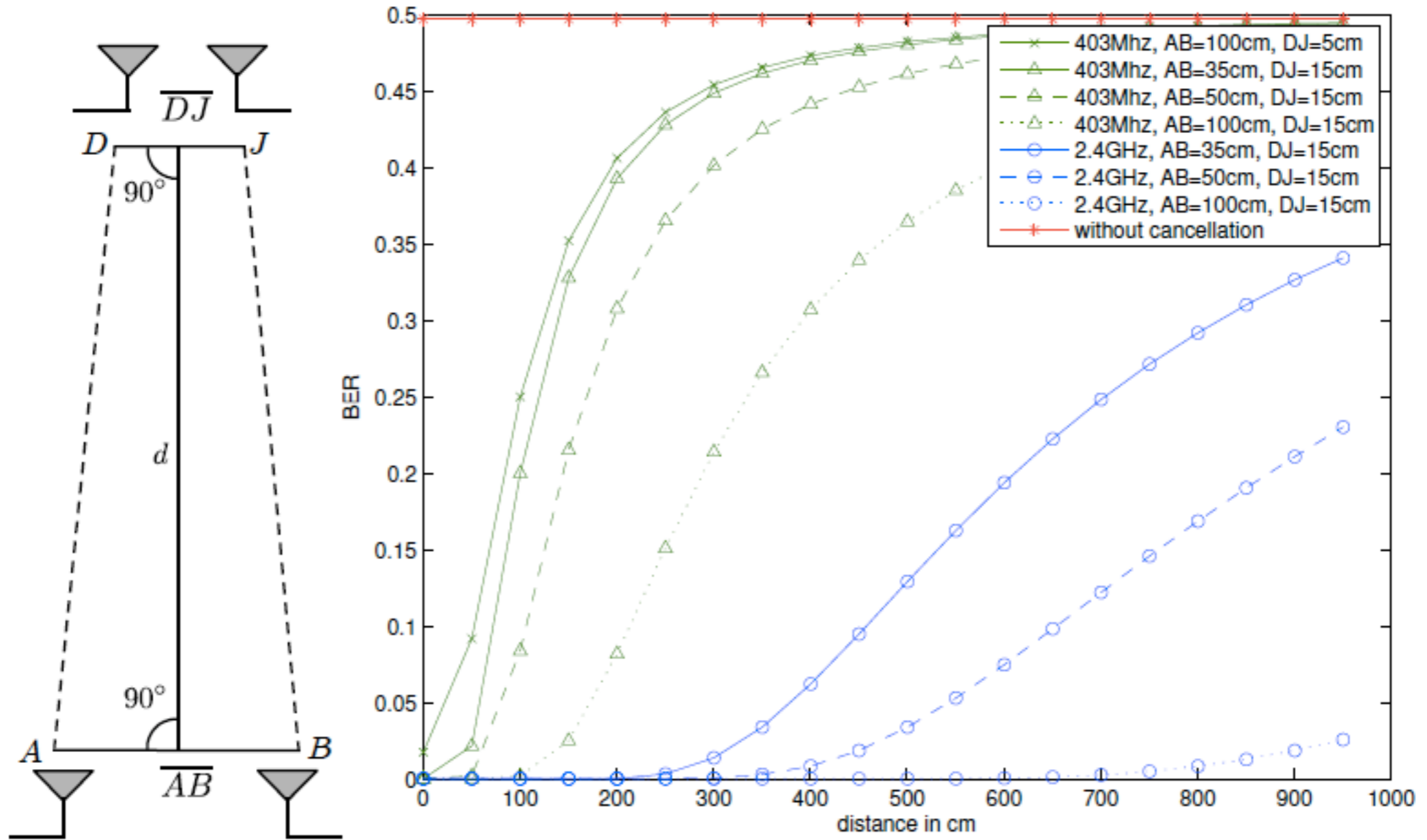

Multipath

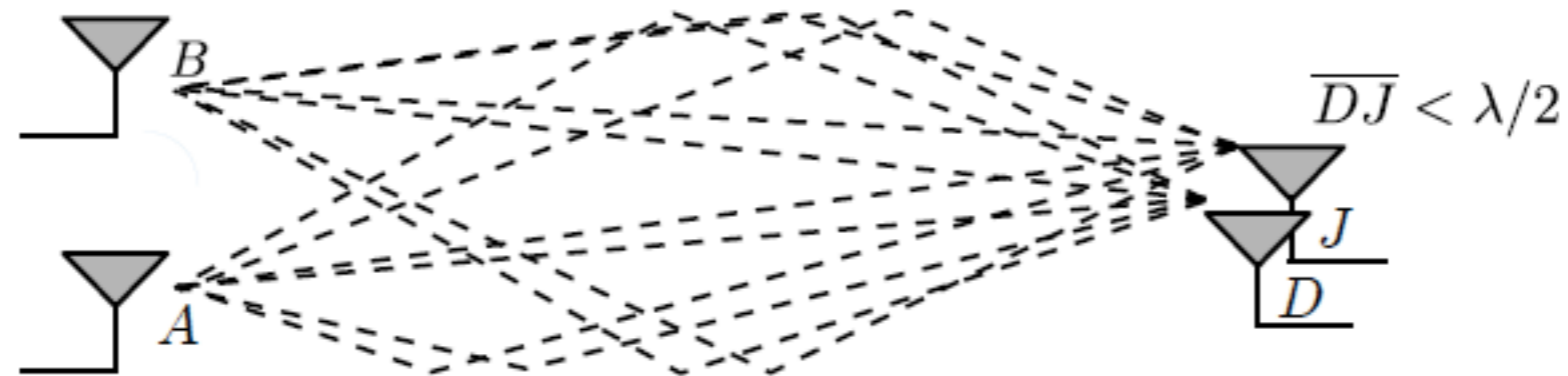

- So far, we looked at LOS channels, no reflections.
- Multipath will introduce more variation of amplitudes of components.
- Change the phase offsets of the signals.
- Potentially prevent us from canceling the jamming signals.

Experimental Results

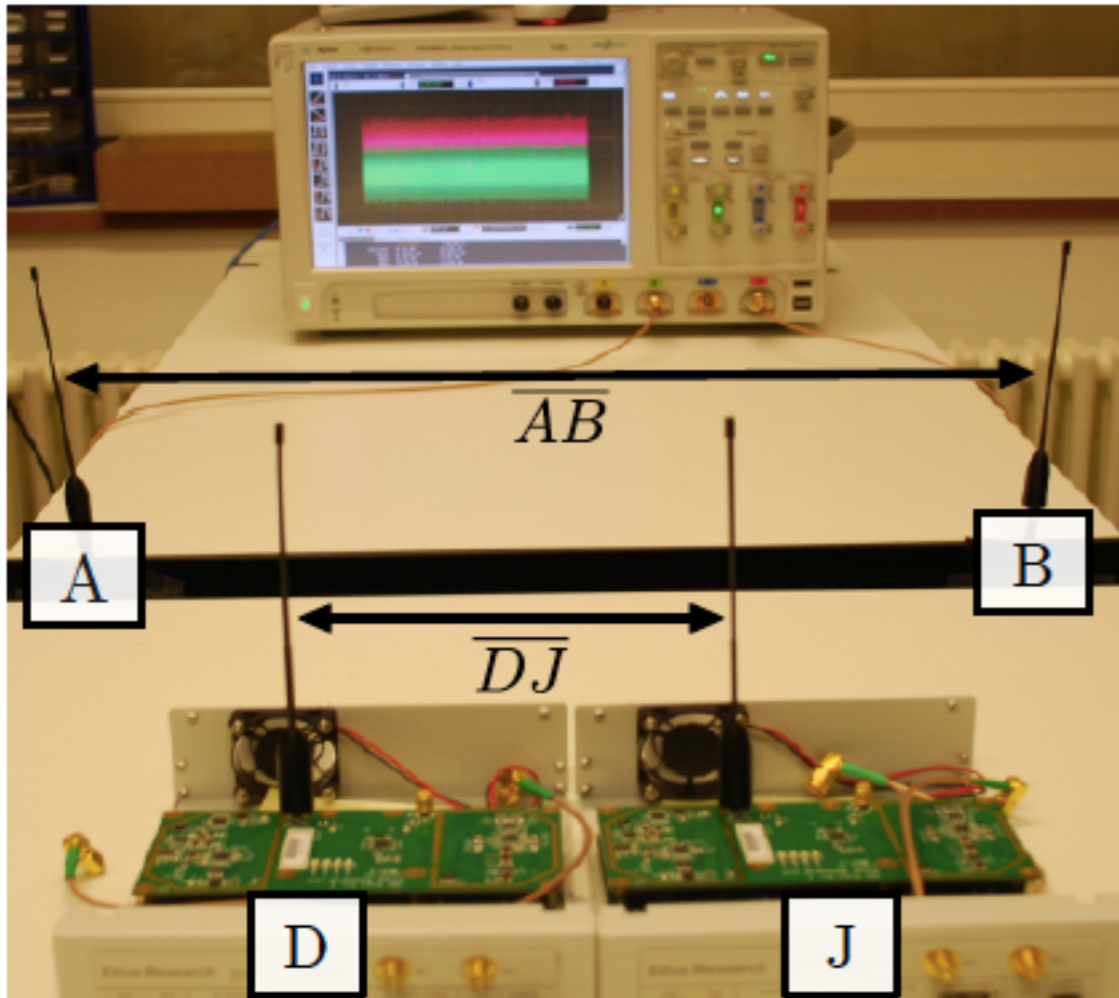

Parameter	Value
<i>Attacker</i>	
Antenna type	Omni-directional vertical
No. of antennas	2
Sampling rate	10 GSa/s
<i>Data transmitter</i>	
Antenna type	Omni-directional vertical
Carrier frequency	403 MHz
Bandwidth (D_{bw})	300 KHz
Packet length	67 bits
Data rate	150 Kbps
<i>Jammer</i>	
Antenna type	Omni-directional vertical
Jamming bandwidth	300 kHz
Noise type	Spectrum shaped random noise
Relative Power of Jammer	{20, 25, 30, 35} dB

Table II

SUMMARY OF THE SYSTEM PARAMETERS IN EXPERIMENTAL SETUP.

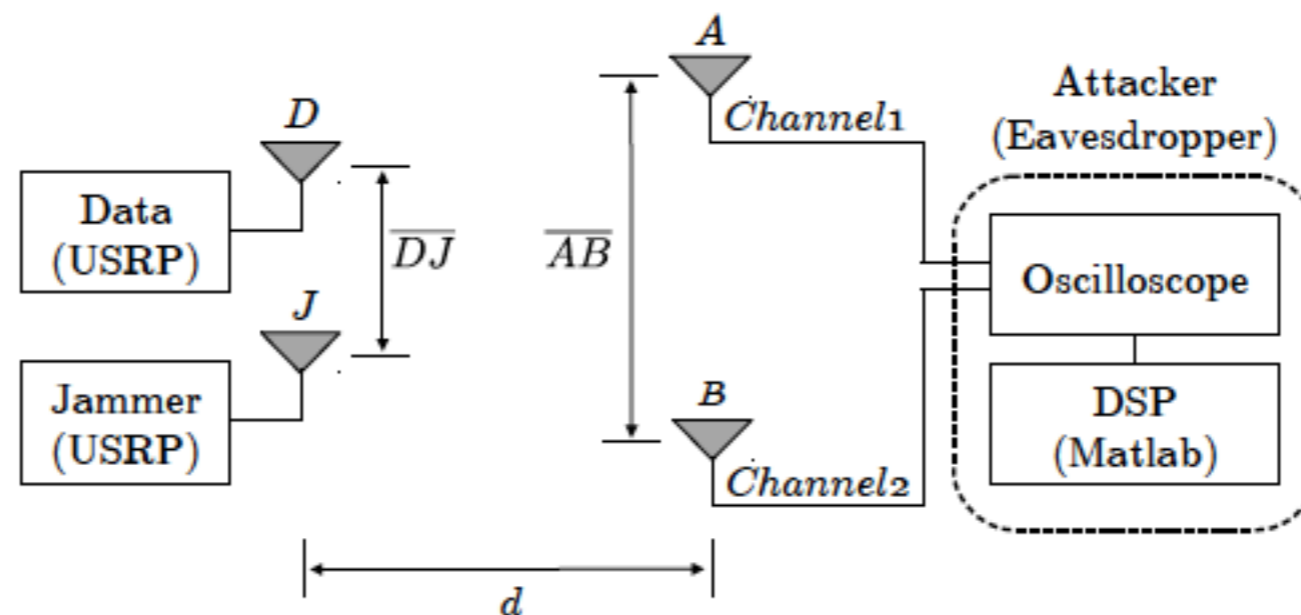

Example Result

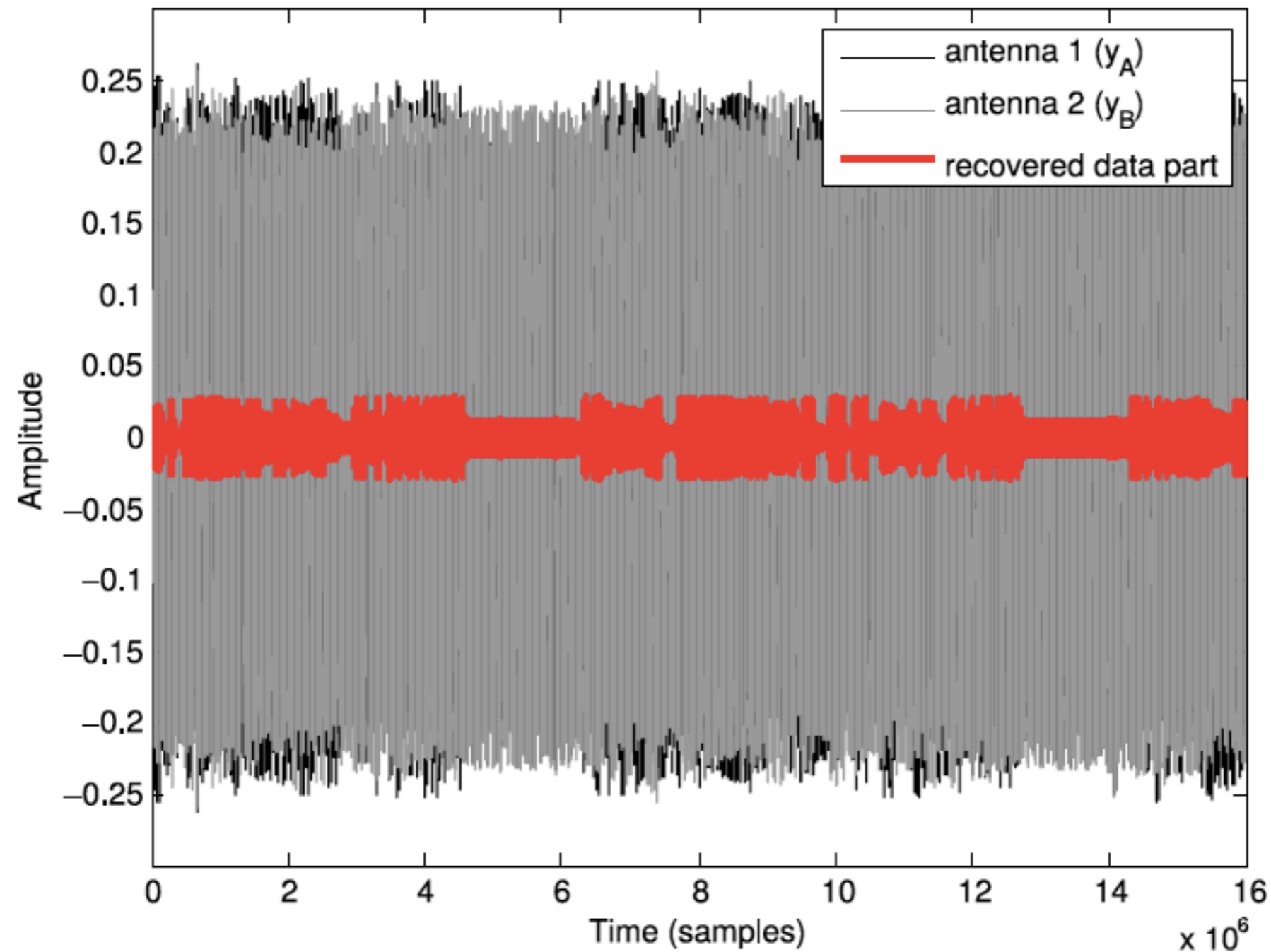
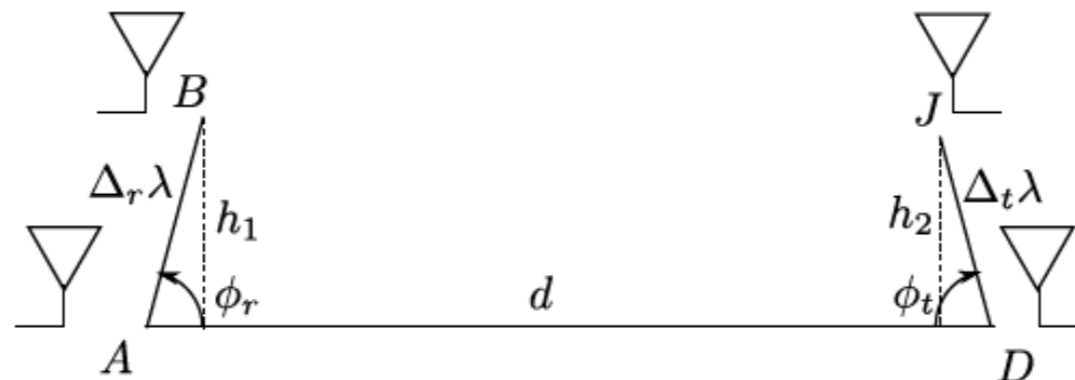
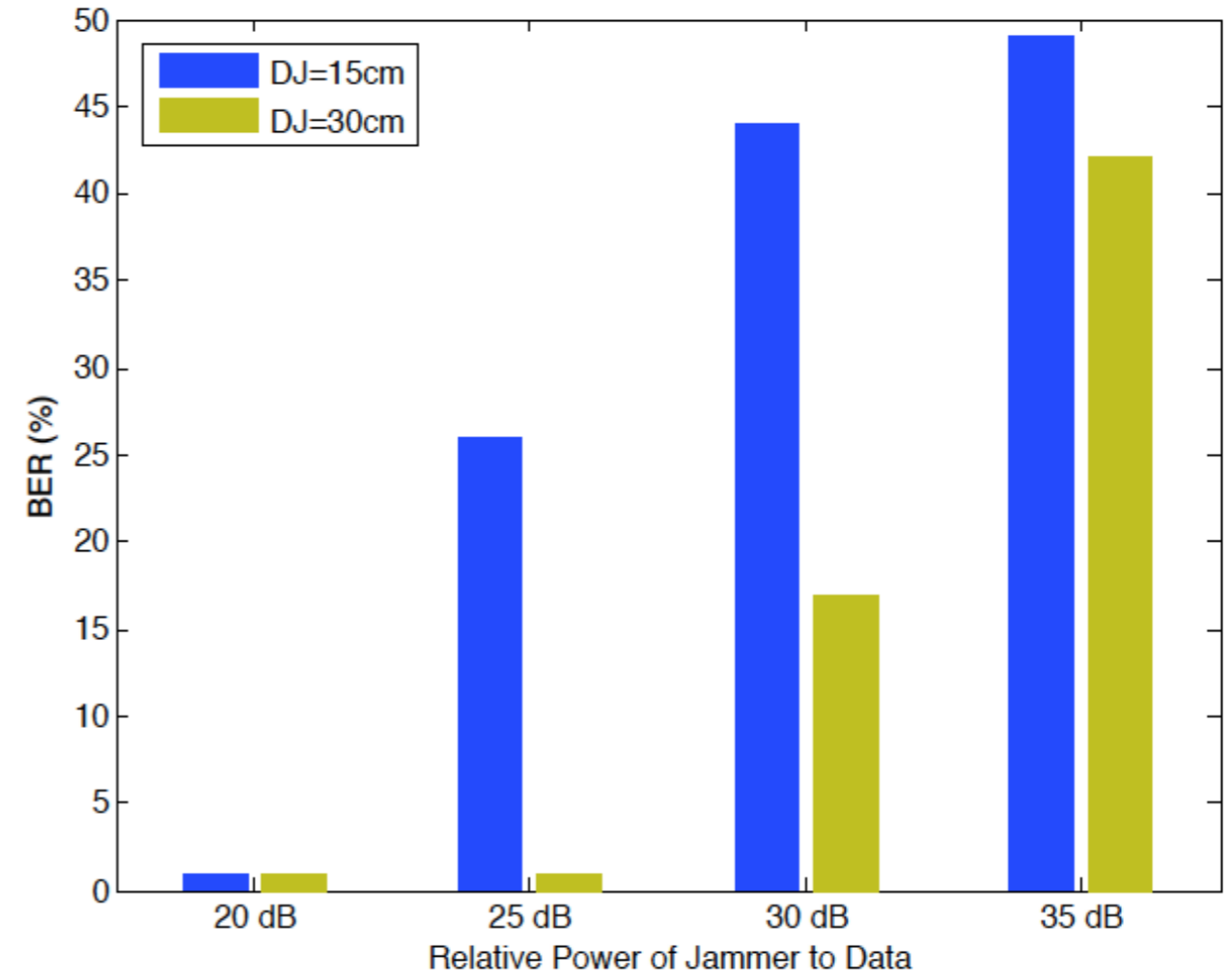
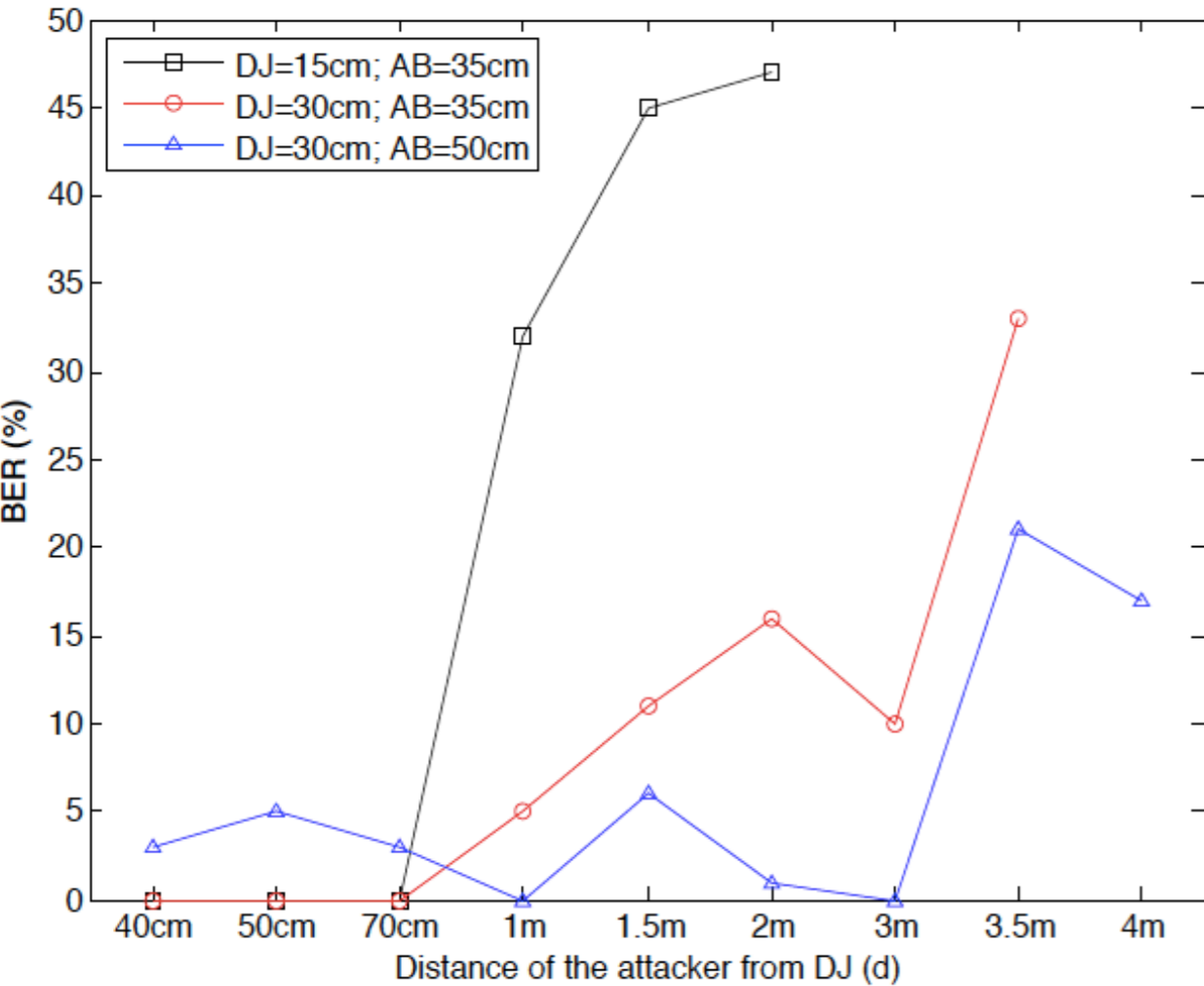

Figure 11. Black and gray waveforms correspond to signals acquired from two receiver antennas. Once the signals were aligned and subtracted, in red we can see the clearly visible, remaining data signal component.

Example Experimental Result



Lessons learned

- **Using Jamming for confidentiality is not without risk**
 - MIMO-like attacker can retrieve data despite $DJ < \lambda/2$.
 - The attack works from many locations (with some post-processing).
 - The attack can be effective even when jammer and source are mobile.
- Note: Friendly Jamming works well for access control.

Can The Attacker Influence the Channel?

Signal Manipulation

- e.g., Signal Annihilation

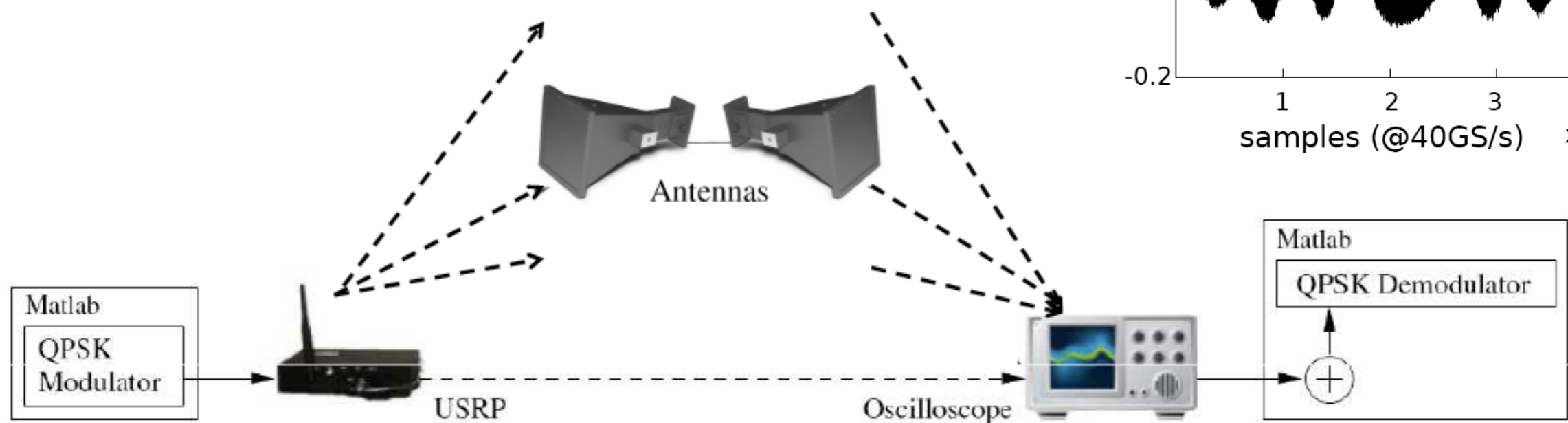
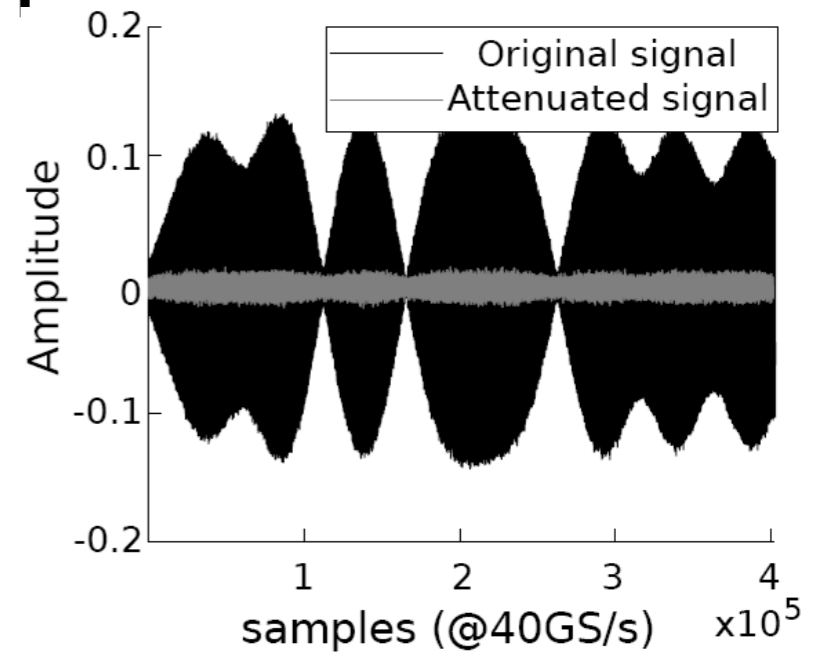

- Simple setup creates artificial multi path that suppresses the transmitted signal at the receiver.
- The receiver does not know that any message was even sent by the transmitter.

Summary

- Using channel characteristics and jamming for confidentiality is secure only in selected scenarios.
- There are many open questions about the utility and the security of the use of physical-layer schemes for confidentiality.
- Given their guarantees, they are likely to be used not as sole but as complementary measures.
- The use of physical-layer schemes for access control seems more realistic and more robust to attacks.

Broadcast Authentication

Integrity Codes: Broadcast Authentication
based on Presence Awareness

Broadcast Authentication

Can we enable broadcast authentication without any pre-shared information?

- No pre-shared secret keys
- No distributed credentials (e.g., certificates/public keys)



Broadcast Authentication

Can we enable broadcast authentication without any pre-shared information?

- No pre-shared secret keys
- No distributed credentials (e.g., certificates/public keys)

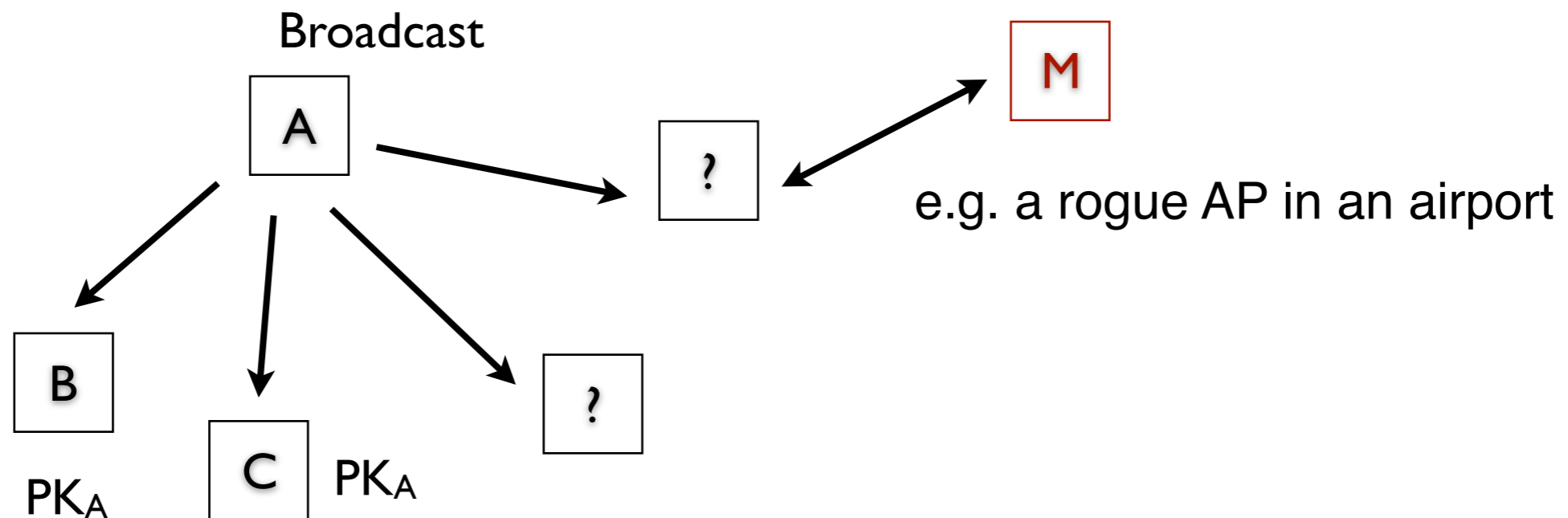

Integrity Codes

Scenario:

- The receiver is in the direct power range of the sender, **and it knows it!**
- E.g., a user walks into a university building equipped with university access points.
- The attacker is not restricted in terms of location or number of devices that it has/deploys.

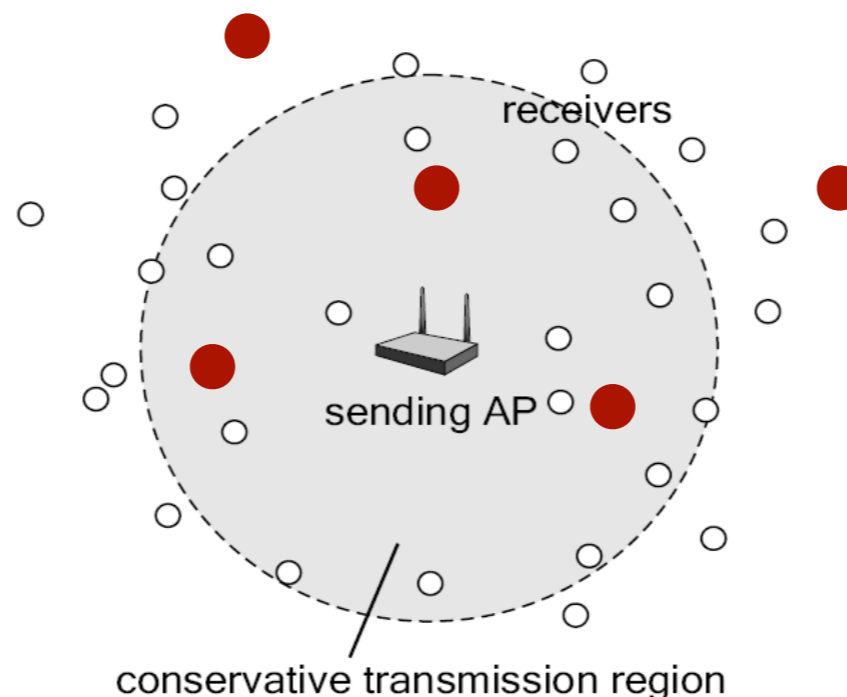

Integrity Codes

Scenario:

- The receiver is in the direct power range of the sender, **and it knows it!**
- The receiver **knows a communication channel** (e.g., channel 5)
- The sender is **always on and transmitting**

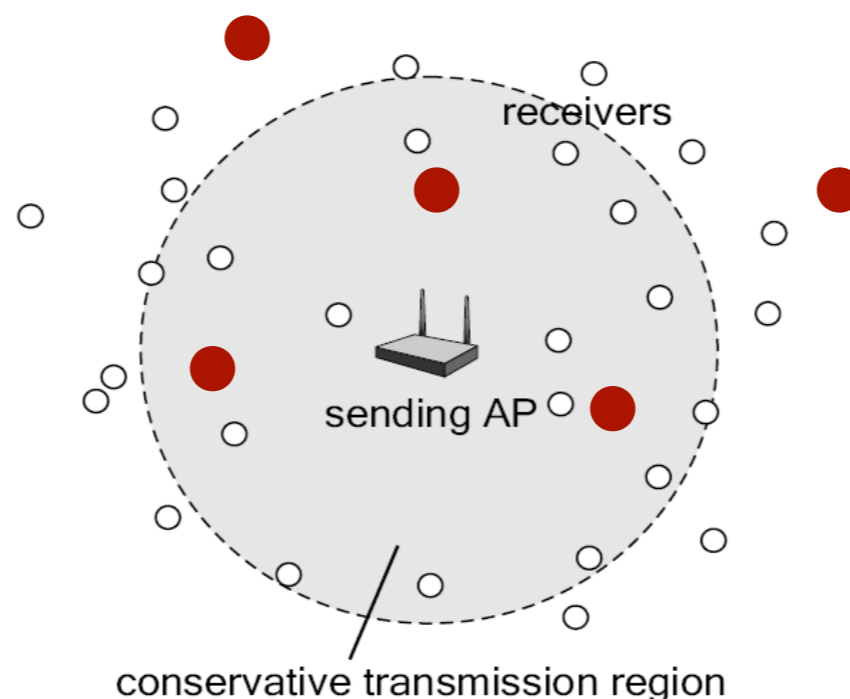

Integrity Codes: Protocol

Transmission (Sender):

- m spread from k bits to $2 \cdot k$ bits ($1 \rightarrow 10$, $0 \rightarrow 01$), $H(m) = k$
- each resulting bit is then transmitted using on-off keying

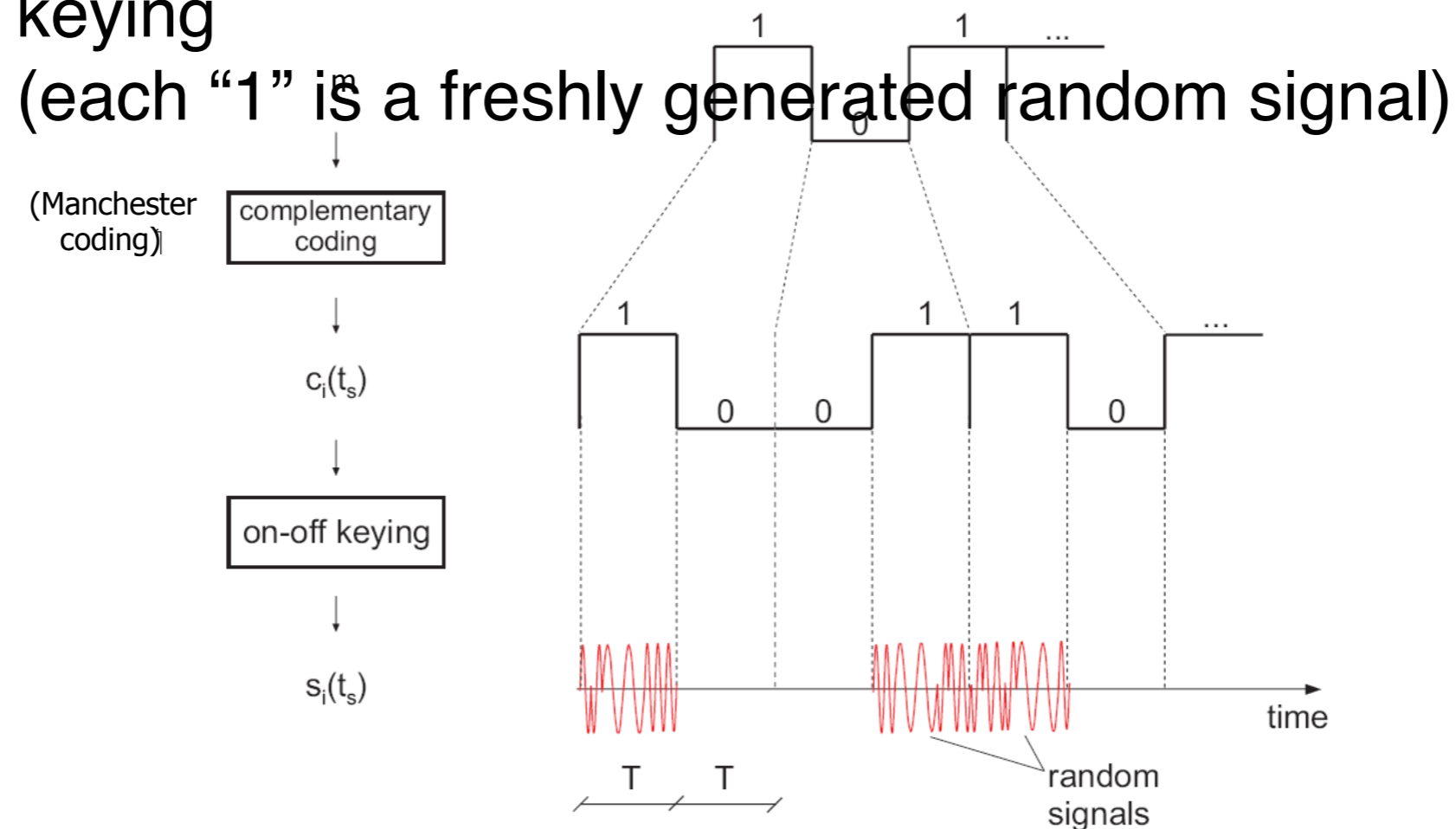

$H(m)$ = the number of bits "1" in m (Hamming weight)

Integrity Codes: Protocol

Reception (Receiver):

- Presence of any signal ($>P_1$) during T interpreted as “1”
Absence of signal ($<P_0$) during T interpreted as “0”

Integrity Verification

- IF $H(m)=|m|/2$ THEN “m” was not modified in transmission

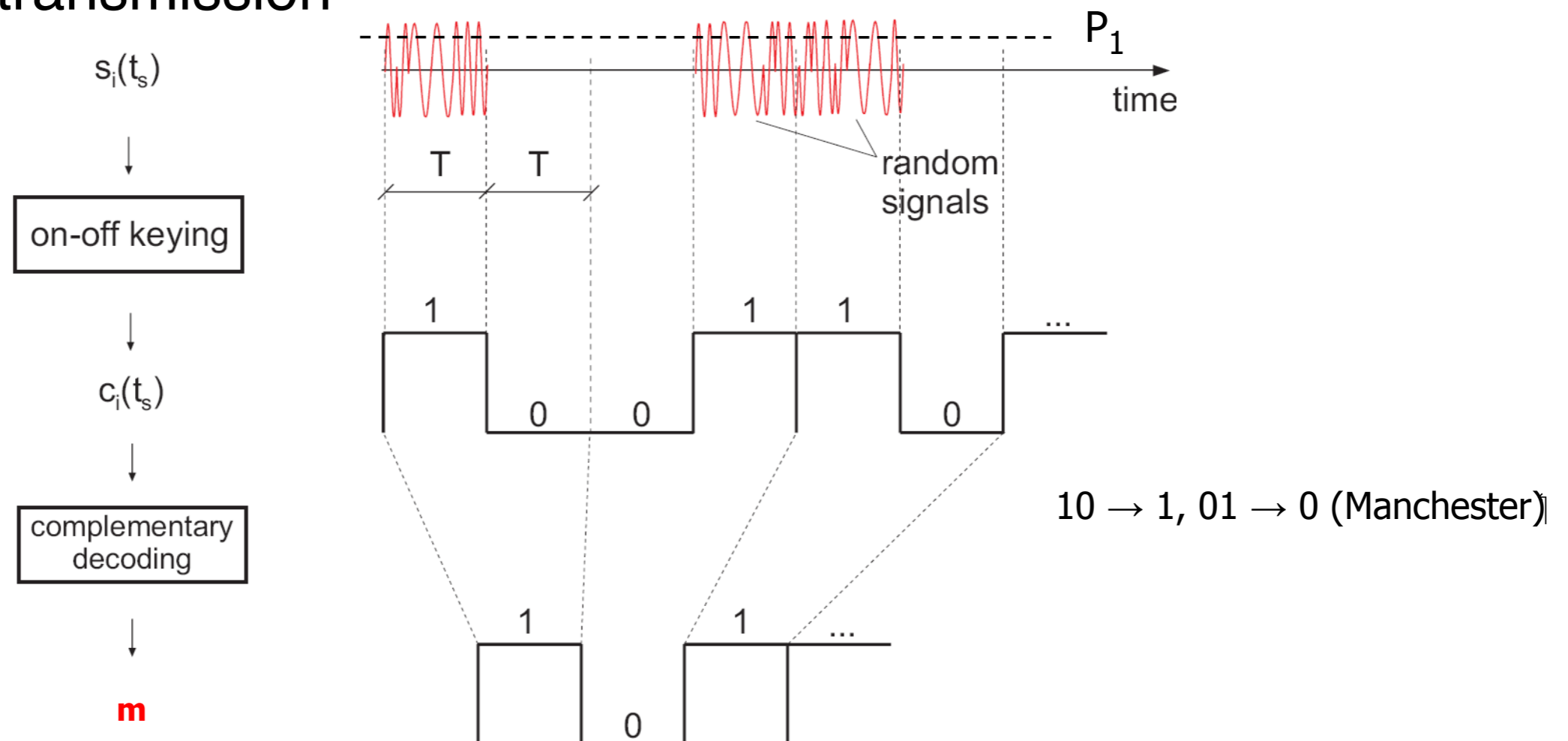

Integrity Codes: **Analysis**

- Message Hamming weight is a public parameter
 $H(m)=2$
 - Attacker can change $0 \rightarrow 1$ and NOT $1 \rightarrow 0$ (except with ε)
 - The sender is permanently transmitting
- \Rightarrow The receiver can therefore detect all modifications of the message

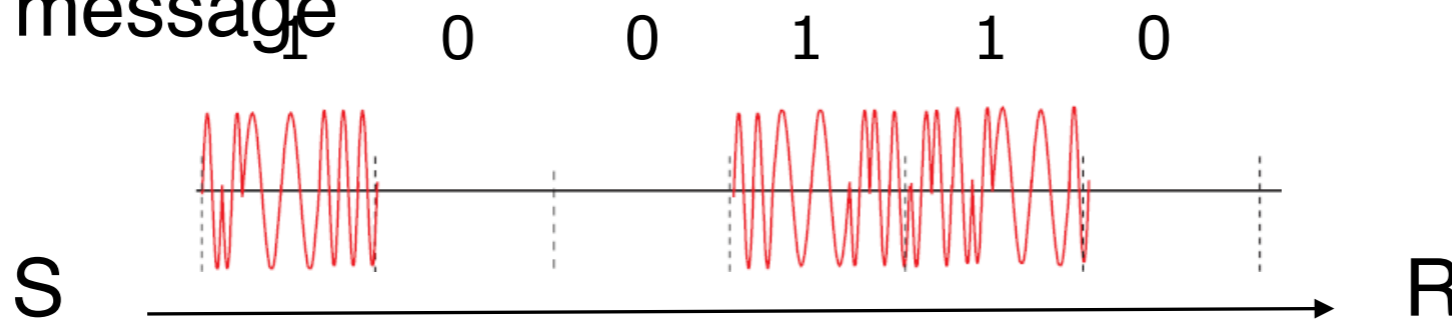

Integrity Codes: **Analysis**

- Message Hamming weight is a public parameter $H(m)=2$
 - Attacker can change $0 \rightarrow 1$ and NOT $1 \rightarrow 0$ (except with ε)
 - The sender is permanently transmitting
- => The receiver can therefore detect all modifications of the message

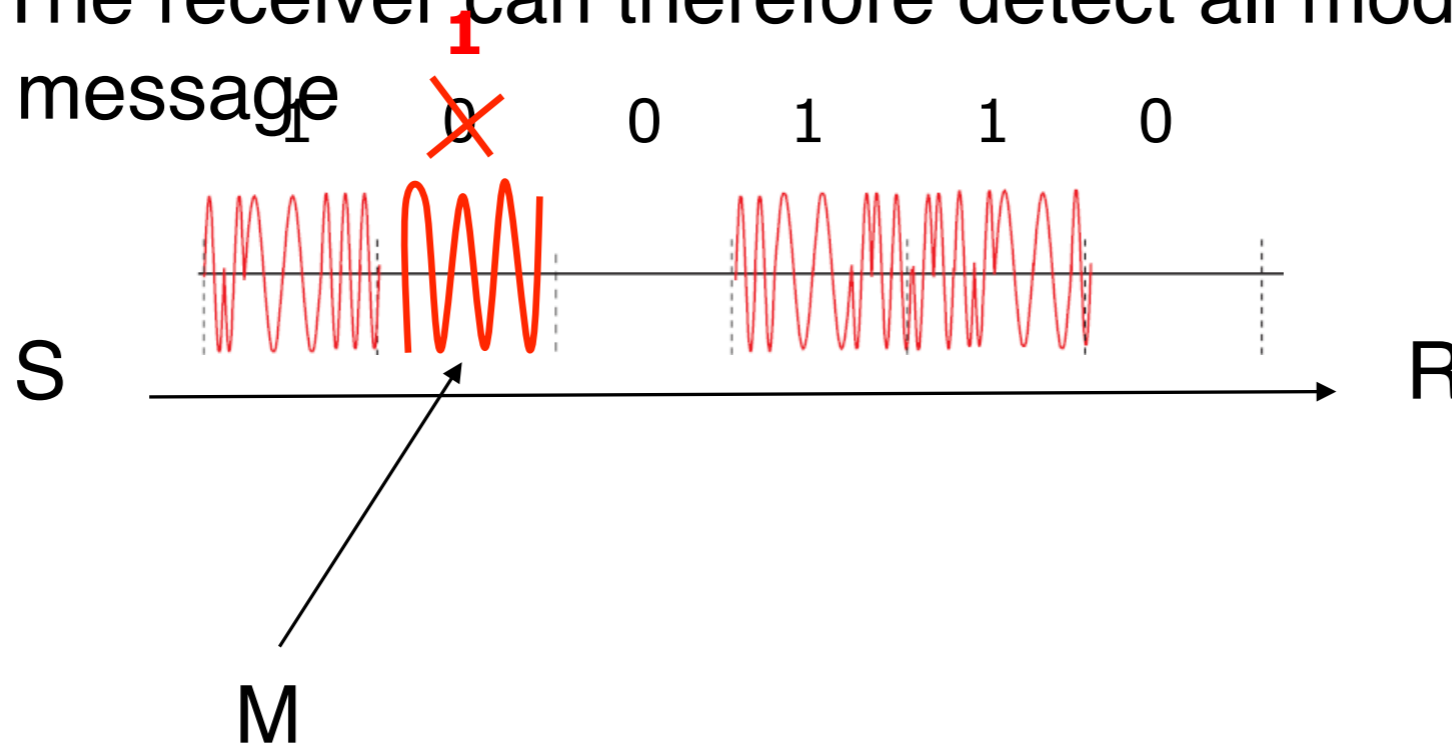

Integrity Codes: **Analysis**

- Message Hamming weight is a public parameter $H(m)=2$
 - Attacker can change $0 \rightarrow 1$ and NOT $1 \rightarrow 0$ (except with ε)
 - The sender is permanently transmitting
- \Rightarrow The receiver can therefore detect all modifications of the message

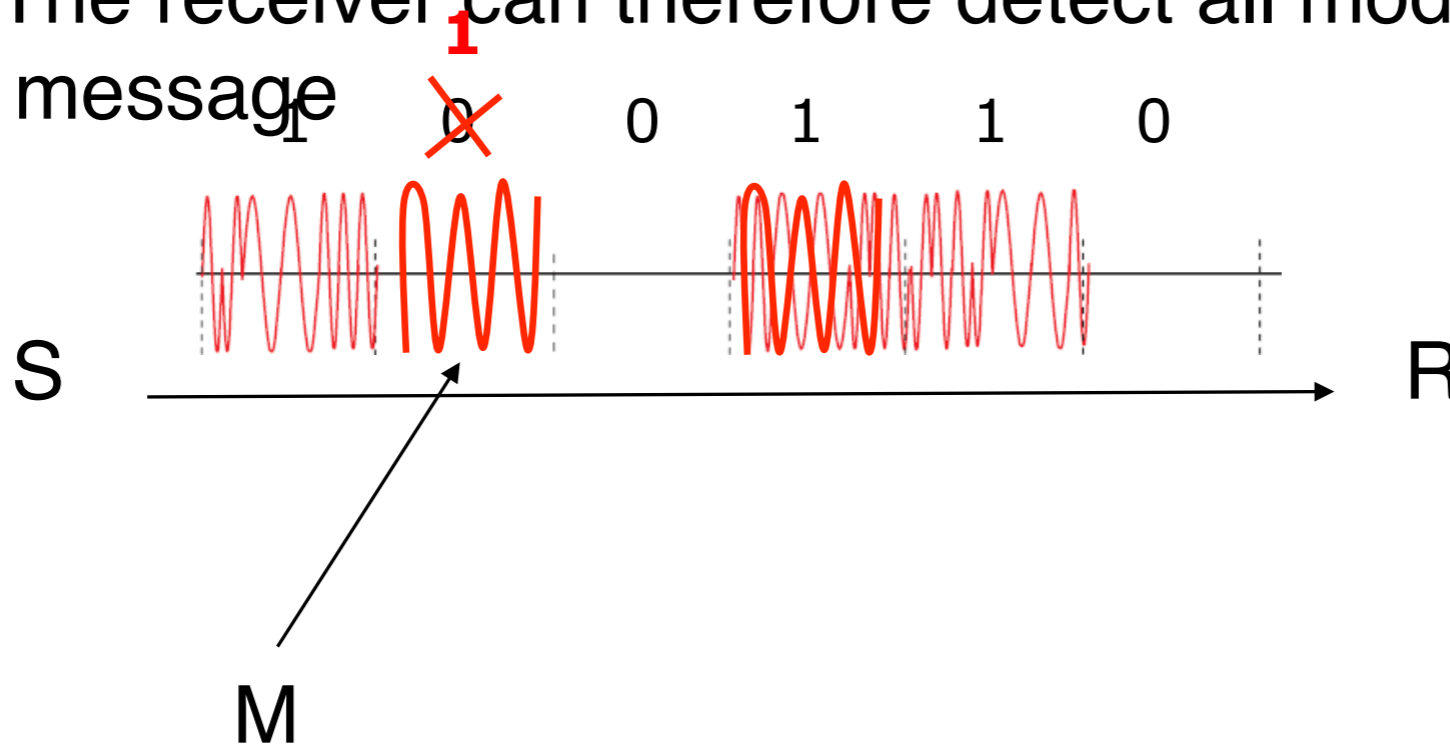

Integrity Codes: Analysis

Probability of signal annihilation $1 \rightarrow 0$

$$\underbrace{r(t)}_{\text{receiver}} = \underbrace{\cos(\omega_0 t)}_{\text{sender}} - \underbrace{\cos(\omega_0 t - \theta)}_{\text{adversary}}, \text{ where } \theta \in [0, 2\pi)$$

$$E_r = \int_0^{T_s} r^2(t) dt$$

$$\approx 2T_s \sin^2\left(\frac{\theta}{2}\right)$$

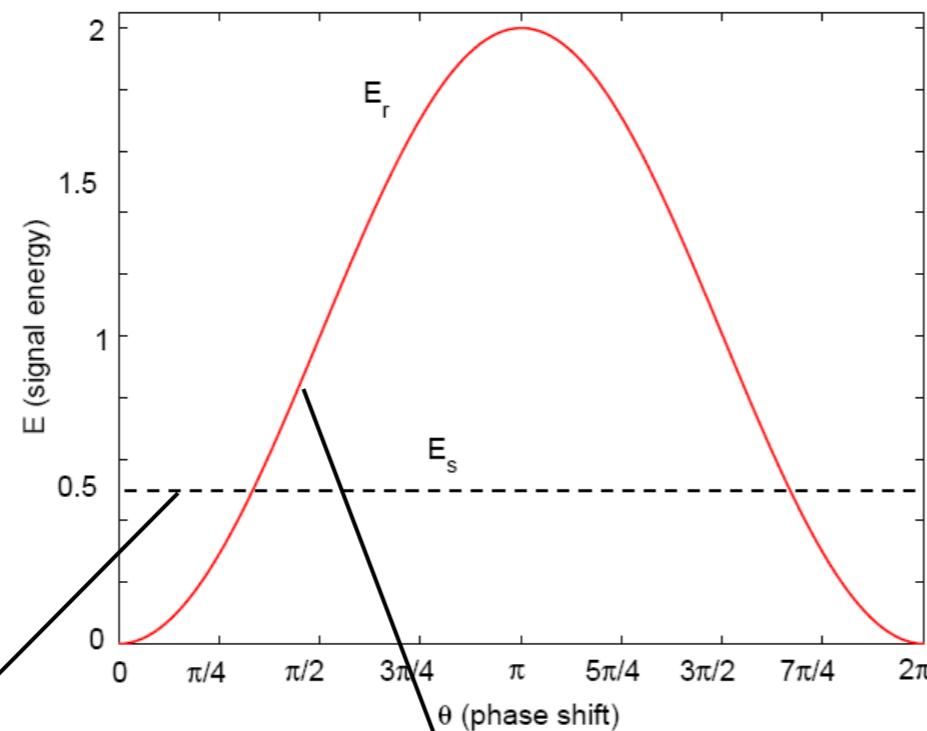

Energy of the sender's signal.

Energy of the combined sender's and adversary's signal.

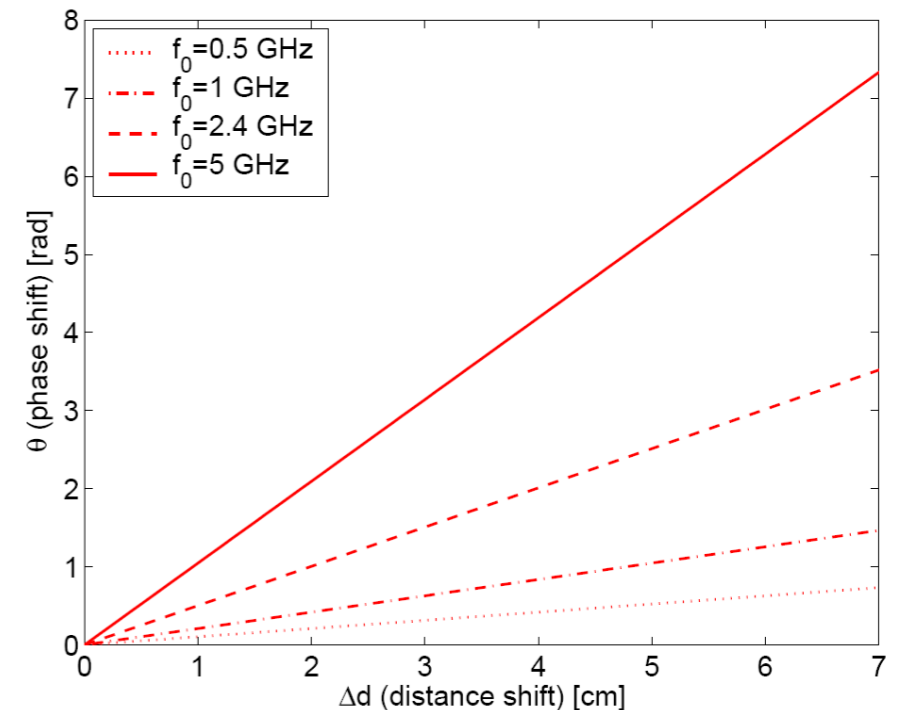

Error in attacker's distance estimation

Integrity Codes: **Analysis**

How can one handle messages of arbitrary sizes?

- Receiver does not have to know the length of the message in advance
- A valid message received between two subsequent *i*-delimiters is authentic.
- For Manchester coding, an optimal integrity-delimiter is simply **111000**

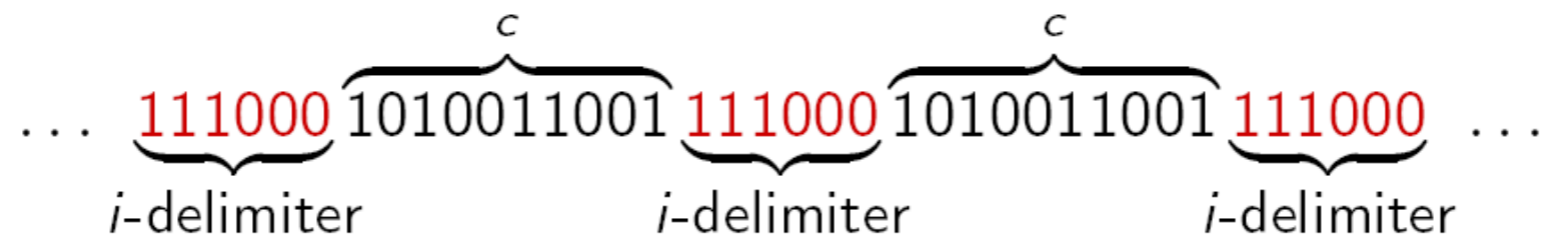

- **“111000”** cannot be a part of any codeword

Integrity Codes: Optimizations

Integrity Coded channel is slow.

